

◆ PRECISION INSTRUMENTS FOR TEST AND MEASUREMENT ◆

# TYPE 1455

## Voltage Divider

### User and Service Manual



Copyright © 2013 IET Labs, Inc.  
Visit [www.ietlabs.com](http://www.ietlabs.com) for manual revision updates

1455 im/November 2013



---

**IET LABS, INC.**

**www.ietlabs.com**  
Email: [info@ietlabs.com](mailto:info@ietlabs.com)  
TEL: (516) 334-5959 • FAX: (516) 334-5988

## **WARRANTY**

We warrant that this product is free from defects in material and workmanship and, when properly used, will perform in accordance with applicable IET specifications. If within one year after original shipment, it is found not to meet this standard, it will be repaired or, at the option of IET, replaced at no charge when returned to IET. Changes in this product not approved by IET or application of voltages or currents greater than those allowed by the specifications shall void this warranty. IET shall not be liable for any indirect, special, or consequential damages, even if notice has been given to the possibility of such damages.

**THIS WARRANTY IS IN LIEU OF ALL OTHER WARRANTIES, EXPRESSED OR IMPLIED, INCLUDING BUT NOT LIMITED TO, ANY IMPLIED WARRANTY OF MERCHANTABILITY OR FITNESS FOR ANY PARTICULAR PURPOSE.**



## **WARNING**



OBSERVE ALL SAFETY RULES  
WHEN WORKING WITH HIGH VOLTAGES OR LINE VOLTAGES.

**Dangerous voltages may be present inside this instrument. Do not open the case  
Refer servicing to qualified personnel**

### **HIGH VOLTAGES MAY BE PRESENT AT THE TERMINALS OF THIS INSTRUMENT**

WHENEVER HAZARDOUS VOLTAGES (> 45 V) ARE USED, TAKE ALL MEASURES TO  
AVOID ACCIDENTAL CONTACT WITH ANY LIVE COMPONENTS.

USE MAXIMUM INSULATION AND MINIMIZE THE USE OF BARE  
CONDUCTORS WHEN USING THIS INSTRUMENT.

**Use extreme caution when working with bare conductors or bus bars.**

WHEN WORKING WITH HIGH VOLTAGES, POST WARNING SIGNS AND  
KEEP UNREQUIRED PERSONNEL SAFELY AWAY.



## **CAUTION**



DO NOT APPLY ANY VOLTAGES OR CURRENTS TO THE TERMINALS OF THIS  
INSTRUMENT IN EXCESS OF THE MAXIMUM LIMITS INDICATED ON  
THE FRONT PANEL OR THE OPERATING GUIDE LABEL.

# Table of Contents

## Chapter 1 Introduction

|                       |   |
|-----------------------|---|
| 1.1 Introduction..... | 1 |
|-----------------------|---|

## Chapter 2 Specifications

|                               |   |
|-------------------------------|---|
| 2.1 Specifications .....      | 2 |
| 2.2 Ordering Information..... | 3 |

## Chapter 3 Operation

|  |   |
|--|---|
| 3.1 Initial Inspection and Setup .....               | 4 |
| 3.2 Connections.....                                 | 4 |
| 3.3 Dial Settings.....                               | 4 |
| 3.4 Typical Uses.....                                | 4 |
| 3.5 Effects of Temperature.....                      | 5 |
| 3.6 Frequency Response .....                         | 6 |
| 3.7 Output Resistance .....                          | 6 |
| 3.8 Circuit Description.....                         | 7 |
| 3.9 Interpretation of Linearity Specifications ..... | 7 |
| 3.10 Environmental Conditions .....                  | 9 |
| 3.11 Storage .....                                   | 9 |

## Chapter 4 Maintenance

|   |    |
|---|----|
| 4.1 Maintainability and Reliability ..... | 10 |
| 4.2 Preventive Maintenance.....           | 10 |
| 4.3 Verification of Performance .....     | 10 |
| 4.3.1 Calibration Interval.....           | 10 |
| 4.3.2 General Considerations.....         | 10 |
| 4.3.3 Calibration Procedure .....         | 11 |
| 4.3.4 Test Equipment .....                | 11 |
| 4.3.5 Test Procedure.....                 | 11 |
| 4.5 Replaceable Parts.....                | 12 |
| 4.4 Schematic.....                        | 13 |

This page is intentionally left blank.

# Chapter 1

## INTRODUCTION

### 1.1 Introduction

The Type 1455 Decade Voltage Divider is a convenient means of obtaining accurately known voltage ratios. Among its many uses are the calibration of voltmeters, linearity measurements on continuously adjustable transformers and potentiometers, measurement of gain and attenuation, the precise measurement of frequency response characteristics of audio frequency networks and the determination of turns ratios in transformers.

Five models are available in order to provide a choice in resolution and impedance level. The high impedance models, Types 1455-AH and -BH, permit greater

applied voltage up to 700 V, while the lowest impedance model, Type 1455-AL has useful accuracy in the radio-frequency range.

These voltage dividers are housed in a 3.5" high cabinet. The beryllium copper binding posts are for general use and connection to the instrument.

The types 1455-AH and -AL have four selector switches for four digit readout. The types 1455-BH and -B have five decade switches for five digit readout. These switches indicate the voltage ratio setting in an in line readout with the decimal point always before the first digit.



**Figure 1-1: 1455 Decade Voltage Divider**

## Chapter 2

# SPECIFICATIONS

For convenience to the user, the pertinent specifications are given in an **OPERATING GUIDE** affixed to the case of the instrument. Figure 2.1 shows a typical example.

### 2.1 Specifications

#### SPECIFICATIONS

| Type   | 1455-AH         | -A              | -AL          | -BH             | -B              |
|--|-----------------|-----------------|--------------|-----------------|-----------------|
| <b>Dials:</b>  | 4               | 4               | 4            | 5               | 5               |
| <b>Input Resistance:</b>   | 100 k $\Omega$  | 10 k $\Omega$   | 1 k $\Omega$ | 100 k $\Omega$  | 10 k $\Omega$   |
| <b>Input Voltage Rating:</b><br>May be 20 ppm linearity change at full rating (see below)  | 700 V           | 230 V           | 70 V         | 700 V           | 230 V           |
| <b>Frequency Response</b> ( $f_o$ at 3 dB down):<br>(unloaded, at max output resistance setting)   | 85 kHz          | 850 kHz         | 7.5 MHz      | 69 kHz          | 690 kHz         |
| <b>Resolution</b> (in ppm of input):   | 100             | 100             | 100          | 10              | 10              |
| <b>Linearity</b>   |                 |                 |              |                 |                 |
| <b>Absolute Linearity</b> (in ppm of input):<br>Output taken with respect to output zero setting at low audio frequencies with input voltage < 1/2 rating. |                 |                 |              |                 |                 |
| <b>Ratio</b>   |                 |                 |              |                 |                 |
| 0.00001 to 0.00010   | —               | —               | —            | $\pm 0.02$      | $\pm 0.03$      |
| 0.00010 to 0.00100   | $\pm 0.2$       | $\pm 0.3$       | $\pm 0.7$    | $\pm 0.2$       | $\pm 0.3$       |
| 0.00100 to 0.01000   | $\pm 2$         | $\pm 2$         | $\pm 3$      | $\pm 2$         | $\pm 2$         |
| 0.01000 to 0.10000   | $\pm 15$        | $\pm 15$        | $\pm 20$     | $\pm 10$        | $\pm 10$        |
| 0.10000 to 1.00000   | $\pm 30$        | $\pm 30$        | $\pm 50$     | $\pm 20$        | $\pm 20$        |
| <b>Terminal Linearity</b> (in ppm of input)<br>(add to absolute linearity):  |                 |                 |              |                 |                 |
| <b>Four-terminal</b> (output with respect to low output terminal):   | $\pm 0.004$     | $\pm 0.04$      | $\pm 0.4$    | $\pm 0.004$     | $\pm 0.04$      |
| <b>Three-terminal</b> (low terminals common, or output with respect to low input terminal):  | $\pm 0.02$      | $\pm 0.2$       | $\pm 2$      | $\pm 0.02$      | $\pm 0.2$       |
| <b>Max Output Resistance:</b><br>(input shorted)   | 27.9 k $\Omega$ | 2.79 k $\Omega$ | 333 $\Omega$ | 28.8 k $\Omega$ | 2.88 k $\Omega$ |
| <b>Effective Output Capacitance:</b><br>(typical, unloaded)  | 67 pF           | 67 pF           | 67 pF        | 80 pF           | 80 pF           |



**Frequency Characteristic:**

Acts like simple RC circuit below  $f_o$  so that

$$\frac{E_o}{E_{in}} = \frac{\text{reading}}{\sqrt{1 + \left(\frac{f}{f_o}\right)^2}}$$

Tabulated value of  $f_o$  is at setting that gives max output resistance so that  $f_o$  at all other settings is higher. At  $0.044f_o$ , response is down  $< 0.1\%$ .

**Accuracy of Input Resistance:**  $+0.015\%$ , except for 1455-AL, which is  $+0.025\%$ .

**Temperature Coefficient:**  $< 20$  ppm for each resistor. Since voltage ratios are determined by

resistors of similar construction, net ambient temperature effects are very small.

**Dimensions** (width  $\times$  height  $\times$  depth): Rack models,  $19 \times 3\frac{1}{2} \times 4\frac{5}{8}$  in. ( $485 \times 89 \times 120$  mm); 4-dial bench models,  $14\frac{3}{4} \times 3\frac{1}{2} \times 6$  in. ( $375 \times 89 \times 155$  mm); 5-dial bench models,  $17\frac{5}{16} \times 3\frac{1}{2} \times 6$  in. ( $455 \times 89 \times 155$  mm).

**Net Weight:** Bench models, 4-dial,  $6\frac{3}{4}$  lb (3.1 kg); 5-dial,  $7\frac{3}{4}$  lb (3.6 kg).

**Shipping Weight** (est): Bench models, 4-dial,  $7\frac{1}{2}$  lb (3.5 kg); 5-dial,  $8\frac{1}{2}$  lb (3.9 kg).

Add approx 1 lb (0.5 kg) to net and shipping weights for rack models.

## Ordering Information

| Model     | Type    | Number of decades | Ratio Range   |
|-----------|---------|-------------------|---------------|
| 1455-9700 | 1455-A  | 4                 | .0001 to 1.0  |
| 1455-9702 | 1455-AH | 4                 | .0001 to 1.0  |
| 1455-9704 | 1455-AL | 4                 | .0001 to 1.0  |
| 1455-9706 | 1455-B  | 5                 | .00001 to 1.0 |
| 1455-9708 | 1455-BH | 5                 | .00001 to 1.0 |

## Chapter 3

# OPERATION

### 3.1 Initial Inspection and Setup

This instrument was carefully inspected before shipment. It should be in proper electrical and mechanical order upon receipt.

An **OPERATING GUIDE** is attached to the case of the instrument to provide ready reference to specifications.

Remember that the voltage divider, like any potentiometer, should be used only with high resistance loads.

### 3.2 Connections

Connect the external voltage source to the two insulated INPUT terminals. If grounded operation is to be used, connect the ground link between the lower INPUT grounded terminal and the middle insulated terminal. Connect the device to be supplied to the OUTPUT terminals.

For additional flexibility and range, each decade provides a "10" position setting. This "10" position on any one decade equals the "1" position on the next higher decade. It adds about 11% to the nominal total decade resistance.

### 3.3 Dial Setting

Set the selector switches to indicate the desired voltage ratio. When setting the switches remember that the  $X = 10$  and the decimal point is always placed before the first digit. For example, if the output voltage is to be 0.1240 times the input voltage, the switches can be set from left to right respectively to:

1, 2, 4, 0

or

1, 2, 3, X

If a ratio of 1.0000 is desired, set the switches to:

9, 9, 9, X

### 3.4 Typical Uses

#### Calibration of a Voltmeter

The simple circuit of Figure 3-1 is useful for checking electronic, low frequency ac or dc voltmeters which have an input impedance much higher than the output impedance of the divider. The Type 1455-AL is particularly useful for low voltage ac calibration because of its lower output impedance and better frequency characteristics. In this circuit, the standard meter should be used with a reading near full scale to obtain the best accuracy.

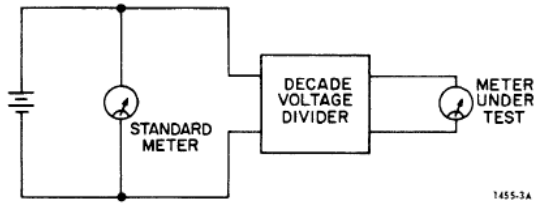

Figure 3-1 Voltmeter Calibration

### Linearity Checks of a Potentiometer

The linearity of potentiometers and other voltage dividers can be checked using the circuits shown in Figure 3-2 and Figure 3-3. Both circuits are essentially Wheatstone bridges.

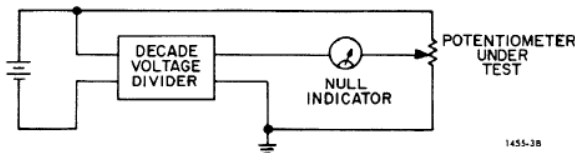

Figure 3-2 The 1455 Decade Voltage Divider in null circuit

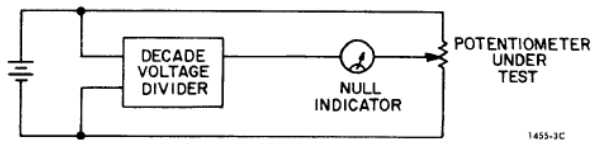

Figure 3-3 Null circuit for linearity test of a low resistance potentiometer

The circuit of Figure 3-3 is preferable if the impedance of the device under test is lower than that of the divider. In either of these circuits, when the divider is adjusted to give a null indication, no current is drawn from the divider and the open circuit calibration is correct.

These circuits may also be useful at audio frequencies, but capacitive loading effects must be considered in order to obtain a null, and to obtain the desired accuracy at a null. The null detector should either be battery operated and floating (GR 1232 Tuned Amplifier and Null Detector) or isolated from the circuit by a shield

transformer (GR 578 Shielded Transformer) In either case, the larger output capacitance should be placed across the device with the lower output impedance in order to reduce loading and phase shift errors. It may be necessary to add additional capacitance to obtain a null.

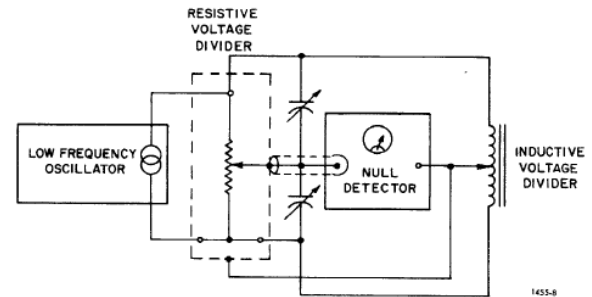

Figure 3-4 An ac null circuit for linearity tests

An example of an ac circuit is shown in Figure 3-4. Here, the transformer type divider has a much lower output impedance than that of the resistive divider so that the low side of the detector and the case of the resistive divider are both tied to the output.

### 3.5 Effects of Temperature

Since all resistors are of similar construction and have more or less equal temperature coefficients, the effects of changes in ambient temperature are very small. The effects from self heating are not balanced out, however. In figure 3-5, note that in the first decade between contacts 7 and 9, which are bridged by the second decade, only half of the input current is carried. The resistors between these points will have only one quarter of the temperature rise of the other resistors in the decade, causing an error in output voltage. The temperature rise of the following decade is negligible. The temperature effect is greatest at the zero position of the first decade.

To keep the self heating error at the first decade within specifications, limit the input voltage to the divider to  $\frac{1}{2}$  of the maximum voltage rating. In dc measurements at very low levels, substantial error can result from thermal emf's at the junctions of dissimilar

metals. The 1455 uses beryllium copper binding posts to minimize these voltages when connections are made with copper wire.

### 3.6 Frequency Response

The Type 1455 acts very much like a simple low pass filter at frequencies below their 3 dB cutoff frequency ( $f_o$ ). Thus, attenuation at any frequency below  $f_o$  can be determined from the expression:

$$\frac{E_{out}}{E_{in}} = \frac{N}{\sqrt{1 + \left(\frac{f}{f_o}\right)^2}}$$

where:

N = divider setting

f = operating frequency

In the specifications, the value of  $f_o$  is given for the setting which gives the maximum output resistance with no additional capacitance on the OUTPUT terminals, and with the case connected to the low INPUT terminal. For any other setting,  $f_o$  is higher, and additional capacitance on the output will reduce  $f_o$  which is inversely proportional to  $R_{out} \times C_{out}$ . The effective internal loading capacitance is given in the specifications to facilitate the calculation of values of  $f_o$  when external capacitance is added.

In some measurement circuits, such as the circuit shown in Figure 3-4, it is possible to connect the divider case to a voltage equal to the output voltage. This greatly reduces the effect of stray capacitance and makes it possible to obtain extremely precise ac measurements even with the high resistance models 1455-AH and 1455-BH.

At setting near zero, the inductance of the wiring, approximately 0.7  $\mu$ H. introduces a small error which is proportional to frequency and is equal to approximately 0.1 ppm at 10 kHz.

### 3.7 Output Resistance

The decimal ratio in the Type 1455 is the ratio of the open circuit output voltage to the input voltage. The divider is intended primarily for use with high impedance loads, such as a null indicator or high impedance voltmeter. For finite load resistances, it is necessary to know the output resistance in order to determine the actual output voltage of the divider. The loaded output voltage ( $E_o$ ) can be determined by the expression:

$$E_o = N \frac{R_L}{R_L + R_o}$$

where

N = divider setting

$R_L$  = load resistance

$R_o$  = output resistance

To the first approximation, the output resistance is that of a simple divider see figure 3-5. For this circuit, the input shorted, the output resistance  $R_o$  is:

$$R_o = N(1-N)R_{in}$$

where

N = divider setting

$R_{in}$  = input resistance

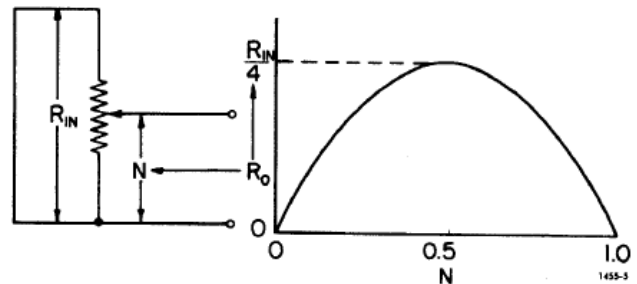

Figure 3-5 Output resistance characteristics of simple divider

The 1455 divider circuit is substantially more complicated than a simple divider and the actual output resistance for any given setting is difficult to calculate. Output resistance values for combinations of the first two digits, with other digits set at zero, are given in Table 3-1 for the Type 1455-A and -B. The output resistance values for the Types -Ah and -BH are those given in Table 3-1 but multiplied by a factor of 10. For the Type 1455-AL multiply by 0.1. Note that it is not possible to interpolate between values given in Table 3-1. The resistance is always increased if subsequent digits are set to other than zero.

|                                 |     | Second Selector – Switch Setting |      |      |      |      |      |      |      |      |      |
|---------------------------------|-----|----------------------------------|------|------|------|------|------|------|------|------|------|
|                                 |     | 0.00                             | 0.01 | 0.02 | 0.03 | 0.04 | 0.05 | 0.06 | 0.07 | 0.08 | 0.09 |
| First Selector – Switch Setting | 0   | 0                                | 189  | 356  | 501  | 624  | 725  | 804  | 861  | 896  | 909  |
|                                 | 0.1 | 900                              | 1069 | 1216 | 1341 | 1444 | 1525 | 1584 | 1621 | 1636 | 1629 |
|                                 | 0.2 | 1600                             | 1749 | 1876 | 1981 | 2064 | 2125 | 2164 | 2181 | 2176 | 2149 |
|                                 | 0.3 | 2100                             | 2229 | 2336 | 2421 | 2484 | 2525 | 2544 | 2541 | 2516 | 2469 |
|                                 | 0.4 | 2400                             | 2509 | 2596 | 2661 | 2704 | 2725 | 2724 | 2701 | 2656 | 2589 |
|                                 | 0.5 | 2500                             | 2589 | 2656 | 2701 | 2724 | 2725 | 2704 | 2661 | 2596 | 2509 |
|                                 | 0.6 | 2400                             | 2469 | 2516 | 2541 | 2544 | 2525 | 2484 | 2421 | 2336 | 2229 |
|                                 | 0.7 | 2100                             | 2149 | 2176 | 2181 | 2164 | 2125 | 2064 | 1981 | 1876 | 1749 |
|                                 | 0.8 | 1600                             | 1629 | 1636 | 1621 | 1584 | 1525 | 1444 | 1341 | 1216 | 1069 |
|                                 | 0.9 | 900                              | 909  | 896  | 861  | 804  | 725  | 624  | 501  | 356  | 189  |

\*Values given are for combinations of settings for first two digits, with other digits set at zero. INPUT TERMINALS SHORTED.

Table 3-1 Output Resistances for Types 1455-A, -B

The highest output resistance give in the specifications is at settings 5455 for the four digit dividers and 54545 for the five digit models. Output resistance for other settings may be most easily found by resistance measurements. If the generator has a finite impedance and the voltage is measured before this impedance instead of tat the divider, the ratio with respect to this generator voltage will be in error. However , if the load impedance is infinite, the ratio of any two settings will be correct because the input impedance of an unloaded divider of this type is constant.

If both the generator and load impedances are finite and relative ratios are desired, the equivalent output impedance should be measured with the INPUT terminals connected through an impedance equal to that of the generator, and corrections should be made as shown above.

### 3.8 Circuit Description

The method of voltage division, which is attributed to Kelvin and Varley, is shown by the schematic diagram for the Type 1455-A, Figure 3-6.

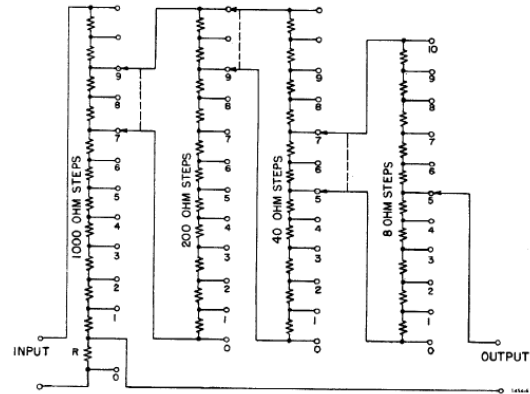

Figure 3-6 Schematic Diagram of 1455-A

Eleven equal resistors are used in all but the last decade. Two of these resistors are shunted by the next decade which uses resistors of one-fifth the value of those in the preceding decade. In this manner, each decade effectively becomes a string of ten equal resistors giving the desired decimal readout on the dial.

The Type 1455-AH uses resistors of ten times the values shown in Figure 3-6. On the Types 1455-AL, -B and -BH additional fixed resistors are added across the input of the later decades in order to avoid the necessity of using very low value resistors which would be less accurate and stable.

### 3.9 Interpretation of Linearity Specifications

#### Linearity and accuracy

The linearity specification for the Type 1455 is given in ppm of the input voltage. This specification is similar to a voltmeter accuracy specification given in percent of full scale. At any setting, the difference

between the input voltage multiplied by the settings and the output voltage will be less than the specified ppm of the input voltage.

In terms of percentage of settings, the accuracy is equal to the specified linearity divided by the setting. Because the setting is never greater than unity, the accuracy as a percentage of setting is always a larger number than the linearity specification. For very low settings the linearity, as a fraction of input, becomes a very small number. The accuracy as a percent of these low settings is actually poorer than that of higher settings, because of somewhat lower tolerance resistors are used on the higher digits.

**Absolute Linearity**

For very low settings, the resistance of the wiring and switches add small, but noticeable errors, because at the zero setting the output is not exactly zero. This error can be ignored if the output at an setting is taken with respect to the actual output at the zero setting. This is shown in Figure 3-7 where the errors are greatly exaggerated for the purpose of illustration. Here the output at full scale does not equal the input. Absolute linearity is a measure of how far the output voltage differs from a straight line drawn between the output voltages at the zero and full scale settings, even though the voltage at the points are not exactly equal to zero and unity.

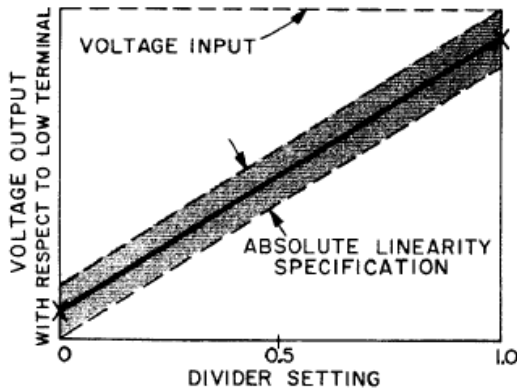

Figure 3-7 Exaggerated illustration of absolute linearity

An example of the use of absolute linearity is the calibration of dividers using lead compensation correction as in Figure 3-8. Potentiometers A and B are adjusted so that the zero and one settings of both dividers coincide.

**Terminal Linearity**

The linearity of a voltage actually presents at two terminals of a divider is called the terminal linearity.

When the output is taken across both OUTPUT terminals, all four divider terminals are in use. An example of a measurement using this four terminal connection is shown in figure 3-1. The error due to switch resistance is compensated for when such a measurement is made. A small resistor, R in Figure 3-6, is added in series with the divider so that the low OUTPUT terminal is at very nearly the same voltage as the high OUTPUT terminal when the divider setting is at zero. This resistor is of the order of 0.001  $\Omega$  and it will not affect calibration of the decade.

In some cases the input and output connections must be tied together, or the output must be taken with respect to the low INPUT terminal. In such three terminal applications, the compensating resistor R in Figure 3-6, is not effective and additional error is given in the specifications under Terminal Linearity. Example of three terminal operation are the comparison of two dividers and checking the linearity of potentiometers using the circuit shown in Figure 3-4. If the potentiometer under test is of high resistance, greater than the input resistance of the divider, there will be less error if it is connected to the low OUTPUT terminal of the divider as shown in Figure 3-3.

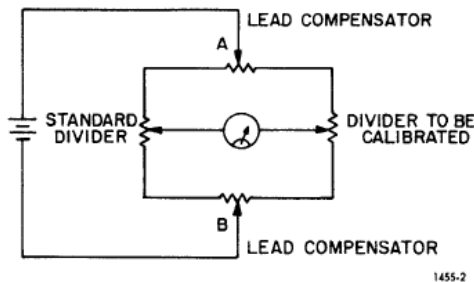

Figure 3-8 Divider calibration, using lead comp.

### **3.10 Environmental Conditions**

For optimal accuracy, the decade box should be used in an environment of 23°C. It should be allowed to stabilize at that temperature after any significant temperature variation.

Humidity should be maintained at <50% RH. This is especially important if high resistances are involved.

### **3.11 Storage**

If this instrument is to be stored for any lengthy period of time, it should be sealed in plastic and stored in a dry location. It should not be subjected to temperature extremes beyond the specifications. Extended exposure to such temperatures can result in an irreversible change in resistance, and require calibration.

## Chapter 4

# MAINTENANCE

### 4.1 Maintainability and Reliability

It is possible to maintain Type 1455 indefinitely. It is reliable due to its closed design and sealed switches and resistors. The unit is resistant to electromagnetic interference (EMI) because of its metal enclosure.

### 4.2 Preventive Maintenance

Keep the unit in a clean environment. This will help prevent possible contamination.

The front panel should be periodically cleaned to eliminate any leakage paths from near or around the binding posts. To clean the front panel:

Wipe the front panel clean using alcohol and a lint-free cloth

### 4.3 Verification of Performance

#### 4.3.1 Calibration Interval

The Type 1455 instruments should be verified for performance at a calibration interval of twelve (12) months. This procedure may be carried out by the user if a calibration capability is available, by IET Labs, or by a certified calibration laboratory.

If the user should choose to perform this procedure, then the considerations below should be observed.

#### 4.3.2 General Considerations

It is important, whenever testing the Type 1455 Decade Units, to be very aware of the capabilities and limitations of the test instruments used. A resistance bridge may be employed, and there are direct-reading resistance meters or digital multimeters available that can verify the accuracy of these units, especially when used in conjunction with standards that can serve to confirm or improve the accuracy of the testing instrument

Such test instruments must have a 4:1 TUR capability for each value calibrated. Note that the accuracy varies for different decades. A number of commercial bridges and meters exist that can perform this task; consult IET Labs.

It is important to allow both the testing instrument and the Type 1455 to stabilize for a number of hours at the nominal operating temperature of 23°C, and at nominal laboratory conditions of humidity. There should be no temperature gradients across the unit under test.



**WARNING**

**Connect the G (GND) terminal to earth or other suitable ground in order to maintain the case at a safe voltage.**

**Whenever hazardous voltages (>45 v) are used, take all measures to avoid accidental contact with any live components.**

**Use maximum insulation and minimize the use of bare conductors.**

**REMOVE POWER WHEN ADJUSTING SWITCHES.**

**Post warning signs and keep personnel safely away.**

### 4.3.3 Calibration Procedure

To calibrate the Type 1455, proceed as follows

The following procedure for checking linearity of the Type 1455 is recommended for incoming inspection or periodic operational testing.

### 4.3.4 Test Equipment

The equipment listed in Table 4-1 is recommended for building the test circuit shown in Figure 4-1.

**Table 4-1  
TEST EQUIPMENT**

| <i>Type</i>                             | <i>Minimum Requirements</i>  | <i>Model Recommended*</i> |
|---|--|---------------------------|
| Low-frequency oscillator                | Range: 50 to 100 Hz<br>Accuracy: $\pm 1\%$   | GR 1311                   |
| Amplifier and null detector             | Sensitivity: 0.1 $\mu\text{V}$ over frequency range used.<br>Gain: 120 dB.   | GR 1232                   |
| Decade transformer divider (2 required) | Linearity: $\pm 1$ digit in $10^{-6}$ decade, at 50 to 100 Hz.<br>Phase error: $< 125 \mu\text{rad}$ for ratio settings from 0.001 to 1.0, at 1 kHz. | GR 1493                   |

\*GenRad models, or equivalent.

### 4.3.5 Test Procedure

The circuit shown in Figure 4-1 is recommended for testing linearity of the Type 1455. Other variations of this circuit may be used, provided considerable care is observed in correcting for phase errors, and assuming the equipment used is precise enough for the results desired.

When setting up the circuit in Figure 4-1, it is recommended that the operating frequency be set at 100 Hz. The procedure to check linearity is as follows:

- a. Set the type 1455 for the ratio setting to be checked.
- b. Adjust the settings of the decade transformers to obtain a null.
- c. Observe the difference between the Type 1455 setting and the setting of the decade transformer No. 1. Compare this difference with the linearity tolerance specified for the Type 1455 setting and for the particular model being tested.

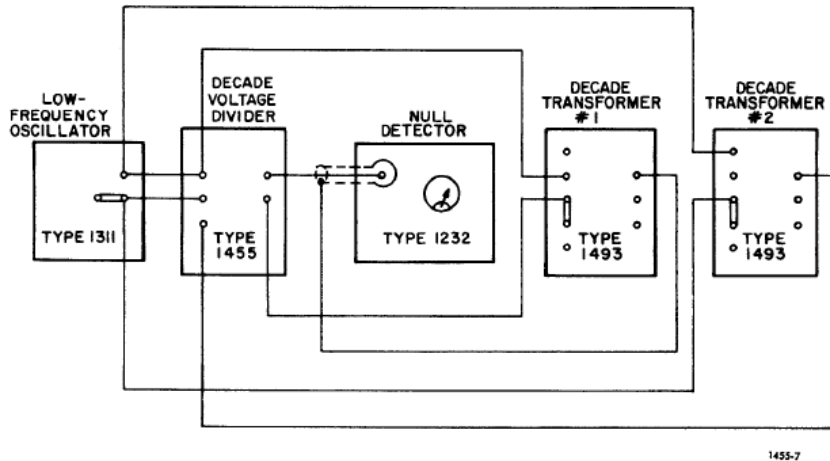

Figure 4-1. Linearity test of a Type 1455 Decade Voltage Divider using a General Radio oscillator, null detector, and two (Type 1493) Precision Decade Transformers.

#### 4.4 Replaceable Parts

##### PARTS LIST

Reference Number used with Type 1455—

| A                            | AH   | AL   | B    | BH   | Description                                     | Part Number |
|------------------------------|------|------|------|------|---|-------------|
| J101                         | J101 | J101 | J101 | J101 | JACK, Binding-post assembly                     | 4060-0108   |
| J102                         | J102 | J102 | J102 | J102 | JACK, Binding-post assembly                     | 4060-0108   |
| J103                         | J103 | J103 | J103 | J103 | JACK, Binding-post assembly                     | 0938-2022   |
| J104                         | J104 | J104 | J104 | J104 | JACK, Binding-post assembly                     | 4060-0108   |
| J105                         | J105 | J105 | J105 | J105 | JACK, Binding-post assembly                     | 4060-0108   |
| R101                         | R101 | R101 | R101 | R101 | RESISTOR, 1.6 m $\Omega$ (part of S101)         | 0510-8140   |
| —                            | —    | R102 | —    | —    | RESISTOR, Wire-wound, 50 $\Omega$ $\pm$ 0.035%  | 0500-0302   |
| —                            | —    | —    | R102 | —    | RESISTOR, Wire-wound, 100 $\Omega$ $\pm$ 0.025% | 0500-0303   |
| —                            | —    | —    | —    | R102 | RESISTOR, Wire-wound, 1 k $\Omega$ $\pm$ 0.05%  | 0510-4870   |
| —                            | —    | R103 | —    | —    | RESISTOR, Wire-wound, 80 $\Omega$ $\pm$ 0.05%   | 0510-4700   |
| —                            | —    | S101 | —    | —    | SWITCH ASSEMBLY, Rotary, 100 $\Omega$ /sect.    | 0510-4964   |
| S101                         | —    | —    | S101 | —    | SWITCH ASSEMBLY, Rotary, 1 k $\Omega$ /sect.    | 0510-4967   |
| —                            | S101 | —    | —    | S101 | SWITCH ASSEMBLY, Rotary, 10 k $\Omega$ /sect.   | 0510-4969   |
| —                            | —    | S102 | —    | —    | SWITCH ASSEMBLY, Rotary, 20 $\Omega$ /sect.     | 0510-4961   |
| S102                         | —    | —    | S102 | —    | SWITCH ASSEMBLY, Rotary, 200 $\Omega$ /sect.    | 0510-4965   |
| —                            | S102 | —    | —    | S102 | SWITCH ASSEMBLY, Rotary, 2 k $\Omega$ /sect.    | 0510-4968   |
| —                            | —    | S103 | —    | —    | SWITCH ASSEMBLY, Rotary, 20 $\Omega$ /sect.     | 0510-4961   |
| S103                         | —    | —    | S103 | —    | SWITCH ASSEMBLY, Rotary, 40 $\Omega$ /sect.     | 0510-4962   |
| —                            | S103 | —    | —    | S103 | SWITCH ASSEMBLY, Rotary, 400 $\Omega$ /sect.    | 0510-4966   |
| S104                         | —    | S104 | —    | —    | SWITCH ASSEMBLY, Rotary, 8 $\Omega$ /sect.      | 0510-4960   |
| —                            | —    | —    | S104 | —    | SWITCH ASSEMBLY, Rotary, 40 $\Omega$ /sect.     | 0510-4962   |
| —                            | S104 | —    | —    | —    | SWITCH ASSEMBLY, Rotary, 80 $\Omega$ /sect.     | 0510-4963   |
| —                            | —    | —    | —    | S104 | SWITCH ASSEMBLY, Rotary, 400 $\Omega$ /sect.    | 0510-4966   |
| —                            | —    | —    | S105 | —    | SWITCH ASSEMBLY, Rotary, 8 $\Omega$ /sect.      | 0510-4960   |
| —                            | —    | —    | —    | S105 | SWITCH ASSEMBLY, Rotary, 80 $\Omega$ /sect.     | 0510-4963   |
| Mechanical Replacement Parts |      |      |      |      | KNOB ASSEMBLY                                   | 5500-5420   |
|                              |      |      |      |      | DIAL ASSEMBLY, 0 to 9                           | 5120-2031   |
|                              |      |      |      |      | DIAL ASSEMBLY, 0 to X                           | 5120-2033   |

NOTE: There are no Federal Stock Numbers for these parts.

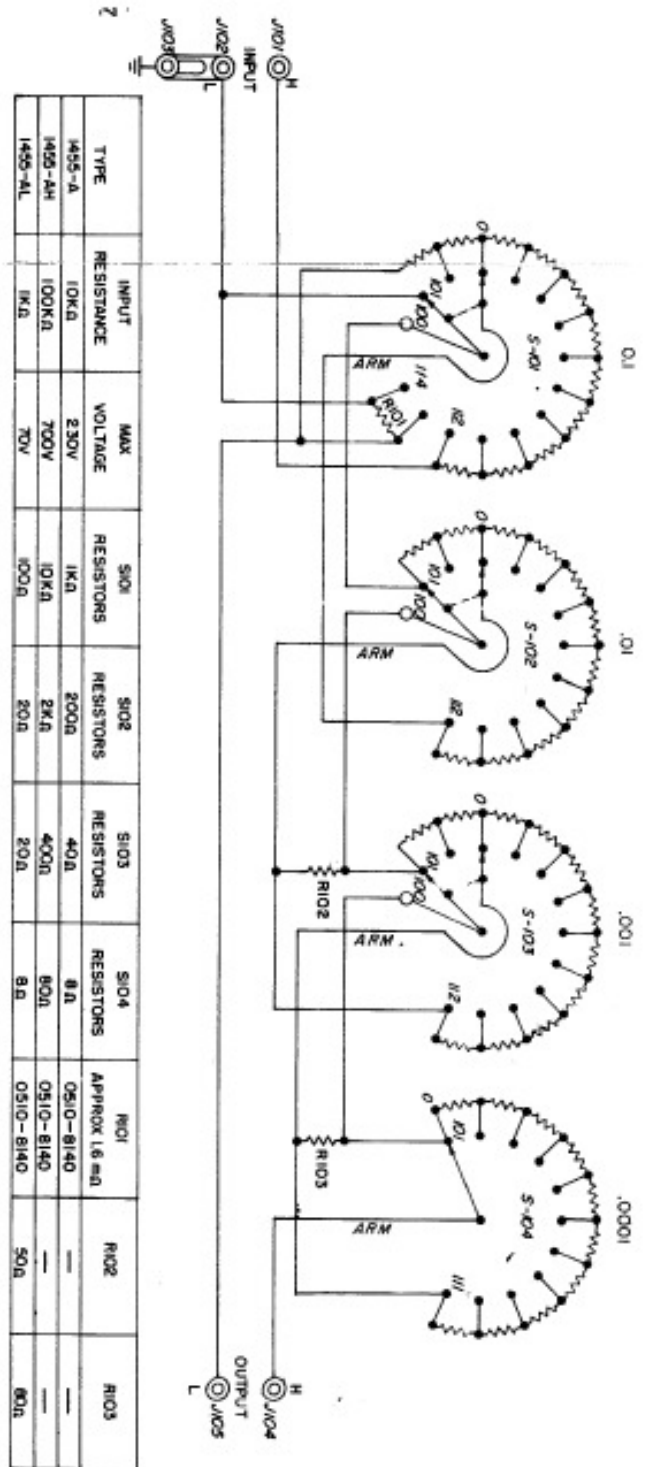

Figure 4-2. Schematic diagram for Type 1455-A, -AH, -AL Decade Voltage Dividers.

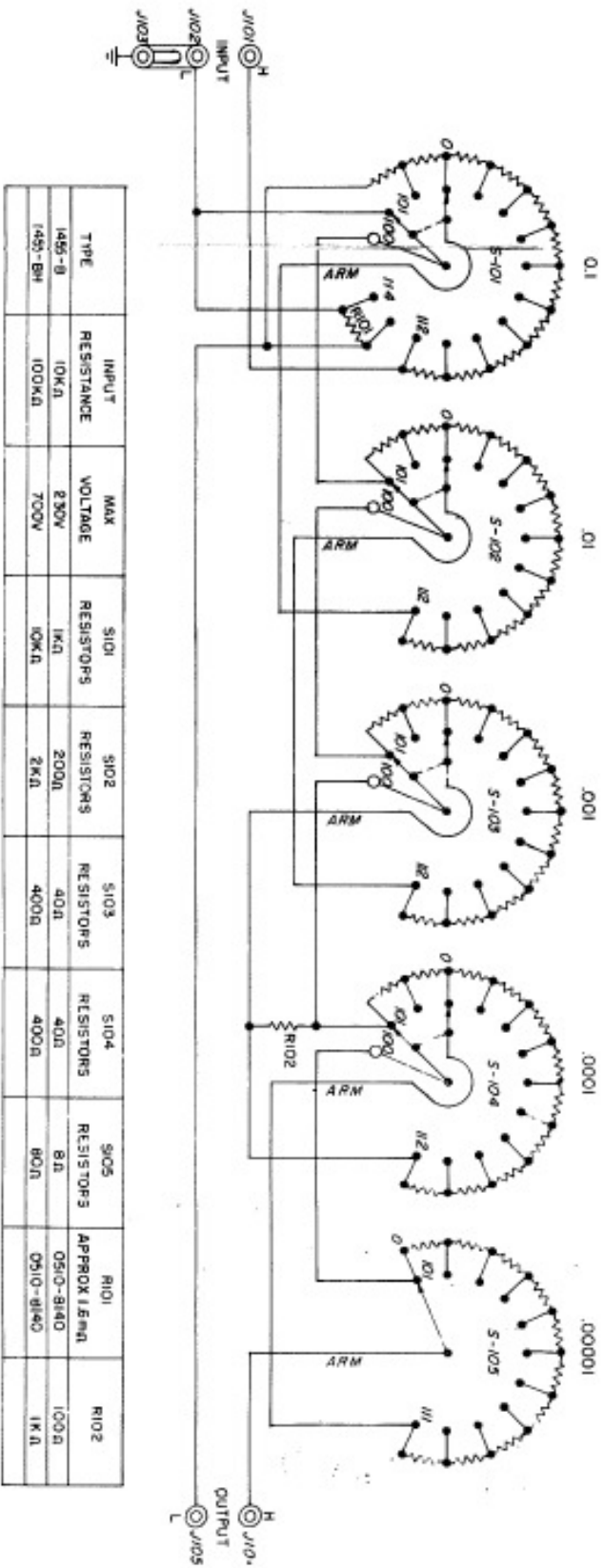

Figure 4-3. Schematic diagram for Type 1455-B, -BH Decade Voltage Dividers.