





Battery Resistance Tester



SBS – 6500

User Manual

Contents

Notes for Safe Operation	5
: WARNING	5
: CAUTION	5
1. Introduction	8
1.1. Battery Condition Determination	8
1.2. Description	9
1.3. Special Features	10
1.5. Dimensions and Weight	15
2. Initial Settings before use	16
2.1. Insert Test Leads	16
2.2. Power ON/OFF 	17
2.3. Real Time Clock Function	17
2.4. Back Light Display 	18
3. Measurement	19
3.1. "0" Point Adjustment Before Measurement	19
3.2. "0 ADJ" 0 Adjustment Procedure (Resistance Measurements)	20
3.3. Measurements	23
3.4. Auto Hold / Record 	25
3.5. Judgment of Battery Condition	27

4. Limit (Comparator)	28
4.1. Limit Judgment Function	28
4.2. Limit Function Operation Procedure	29
4.3. Judgment of Limit.....	30
4.4. LIMIT Function – Audible Tones	31
4.5. Release LIMIT Function	31
5. Data DATA	32
6. Data - Data Base (DDBB) DATA	33
6.1. Data Base Entries	34
6.2. Data Base Functionality	34
6.3. Entry and Deletion of DB Entries	34
7. Data – Recording Function DATA	37
7.1. Record Function.....	38
7.2. Record Memory Matrix.....	38
7.3. Record Display.....	39
7.4. String Set-Up	40
7.5. Recording Address Selection.....	42
7.6. A-REC (Auto Recording)	43
7.7. Review of Recorded Data	44
7.8. Erase of Recorded Data.....	45
7.9. How to Input Reference (Initial) Data	46
7.10. Copy and Paste of Recorded Data	48
8. Data- Table DATA	49
8.1. Recall	49
8.2. Table	50

9. Data – Curve 	52
9.1. Curve (Trend Curve Analysis)	52
10. SBS-2003 Digital Hydrometer SG Upload	54
11. Auxiliary Functions	57
11.1. Auto Power Off	57
11.2. Low Battery Warning	58
11.3. Menu Mode 	58
11.4. HELP 	61
12. SBS Battery Link Software	62
12.1. Description	62
12.2. Suggested Operation System	62
12.3. Connection between the SBS-6500 and the PC	62
12.4. SBS Battery Link - Software Installation Procedure	63
12.5. Un-installation of the SBS Battery Link Software.	65
12.6. Software Instructions	66
12.7. Exiting Software	75
13. Specifications	76
13.1. General Specifications	76
13.2. Electrical Specifications	78
13.3. Accessories	79
14. Maintenance	80
14.1. General Maintenance	80
14.2. Fuse Replacement	81
14.3. Battery Replacement	81

14.4. Troubleshooting	82
14.5. Test Probe Pin Replacement	82
14.6. Cleaning.....	83
14.7. Disposal	83

Notes for Safe Operation

Please review the following items regarding safety in order to prevent damage to the SBS-6500 Battery Resistance Tester or any connecting system. To prevent any potential harm, operate the tester according to the instructions in the manual.



The SBS-6500 is designed and tested according to the International Safety Standard IEC 61010-1 before delivery.

Incorrect or improper measurement methods may cause personal injury or damage to the tester.

[Safety Terms and Symbol]

Technical terms which appear in this manual are listed below.

Before using the tester, please read and follow all safety warnings carefully.

 : Users should read the  marked areas of the manual and pay special attention to the warnings prior to operating the tester.

 : DC (direct current or voltage)

 : Fuse

 : Grounding terminal

: WARNING

“WARNING” statements identify a condition or practice that could result in injury or loss of life.

: CAUTION

“CAUTION” statements identify a condition or practices that could result in damage to the SBS-6500 or other property.

□ **Operation Environment**

- Temperature relative humidity range: 32 to 104 °F (0 to 40°C), max 80%rh (non- condensing)
- Guaranteed accuracy temperature, relative humidity range 65 to 85°F (23±5°C), max 80% rh (non-condensing)
- Please do not expose the SBS-6500 for long periods of time to the following environments which could damage or cause malfunctions/inaccuracies.

☞ *Prolonged exposure to direct sunlight*

☞ *Extremely high temperature*

☞ *Wet environments*

☞ *High humidity and dew*

☞ *Dusty environments*

☞ *Explosive gases*

☞ *Strong electromagnetic fields*

☞ *Near sensitive electronic objects*

☞ *Excessive vibration*

□ **Precautions before use:**

- Upon receipt, inspect the unit and test leads for any signs of physical damage. Notify SBS prior to use of any defect or problem.
- Check the test leads for signs of worn or broken insulation. Worn, abraded or damaged leads should never be repaired. Broken leads should be replaced with new leads only.
- To prevent electric shock, never use any feature of the tester with the covers open.
- To prevent damaging the tester, avoid drops, falls and severe mechanical jolts.

□ **Precautions for Measurements**

To prevent Electric Shock Hazard, please pay attention to the following precautions:

- When measuring internal resistance (impedance), the battery voltage should not exceed 100V DC. When measuring DC Voltages, Input voltage on test leads should not exceed 300V DC.
- Do not measure AC voltages. Unit is designed for DC voltage measurement only.
- Proper polarity of battery test probes (for internal resistance, voltages), and proper connection of the USB Cable (for PC communication).
- Pay special attention to the possibility of a spark when connecting the test leads to the battery. DO NOT TEST in hazardous locations with flammable or explosive gases present.

□ **Cautions for Test Probes**

- For safe and accurate measurements, use only the battery test probes supplied with the SBS-6500.
- To prevent failure of breaking wires, do not pull or fold the test probe cables.
- Tips of test probes are sharp, use care to prevent injury.
- Do not use excessive force which could damage the test probes.

1. Introduction

1.1. Battery Condition Determination

The SBS-6500 is designed to be your best tool for determining the state of health of your battery systems or cells and tracking that history over the entire life of the systems. As batteries age, internal resistance values change in proportion to the condition of the batteries performance capabilities. A rapid increase in internal resistance can indicate a failure is eminent in the near future.

In general, the internal resistance value of a cell or battery will increase by 1.5 to 2 times from the initial value (reference value) when the battery is deteriorating. Regular measurements for comparison will provide warning to take corrective actions prior to its actual failure.

[Judgment of Health (Deterioration)]

- Lead acid storage batteries are common in that they all undergo the same type of plate deterioration over the life span of the battery. This comes in the form of plate structural losses and material corrosions which increase the resistance inside the cell.
- Batteries of the same capacity may have very different initial internal resistance values due to the design, construction and physical number and size of the plates. Comparisons should only be made against that manufacturer's published values or the original installation values for the system.
- The "warning" and "fail" values of batteries from different manufacturers is the same however, it is a percentage change over the life of the battery as it ages.

[Recommendations for Maintenance Activities]

IEEE recommendations and NERC/FERC requirements call for periodic maintenance activities which measure and record this data, as well as cell voltages and temperatures to allow for tracking, charting and analysis of the data to determine how soon system or cell replacement will be required.

[Determination of Battery Replacement Time]

- Based on the specifications of the battery, projected life and actual service life, the trending and graphing of test results can indicate how quickly a battery or battery system should be replaced.
- Proper timing of replacements for failing cells or systems can eliminate an unsuspected or catastrophic, costly failure from occurring. This type of maintenance and data tool allows for pre-planned, budgeted replacement of battery systems before it becomes a matter of urgency.

1.2. Description

- The SBS-6500 was designed for measuring the internal resistance, voltage and temperature of batteries across all applications and types including lead acid cells, nickel-cadmium batteries, lithium-ion batteries and nickel-metal hydride batteries.



SBS-6500

- Measurement data is stored in a 7.5 million data record memory and is transmitted via a USB connection to a PC for printing of reports, graphs and exportation of the data into Excel.
- The unit includes a 200 record programmable reference library of battery reference values for comparison and pass/warning/fail indication at time of testing.

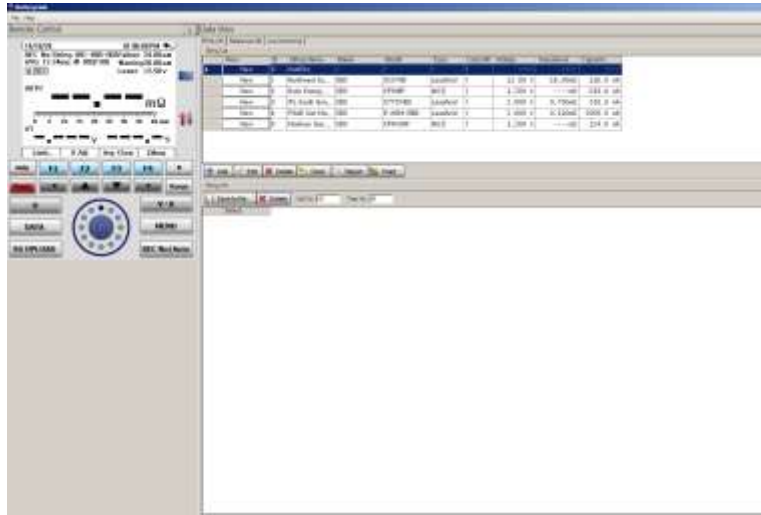

[PC interface]

1.3. Special Features

□ On-Line NON-Destructive Test of Battery Conditions

Using the newest advances in technology, the SBS-6500 measures the data of battery cells and provides a conditional comparison which can be used to determine a batteries current state of health and records data for trend comparisons for the life of the battery string. Method of measurement does not collapse float voltage or discharge the battery to accomplish measurements.

□ Accurate Measurement

AC signal, four-terminal method of measuring the internal resistance. Eliminates lead resistance and contact resistance to achieve the most accurate results.

□ Internal Resistance, Voltage, Temperature Measurements (Simultaneously)

Optional accessories allow for importing specific gravity readings from the SBS-2003 Digital Hydrometer. V/A measurement mode allows unit to be used as a digital multimeter as well as an IR tester.

□ Comparator

Up to 200 sets of reference battery values can be entered in the comparison database. Reference value selection allows for reliable comparison of current readings and the LCD displays pass, warning and fail results and an audible alert for warning and fail results.

□ SD High Capacity Memory

All measurement data (7,530,000 data blocks) including resistance, voltage, temperature, currents, comparator result and specific gravity (data upload from SBS-2003 gravity tester via Bluetooth) can be saved in the internal SD memory of the SBS-6500. This capacity allows a history archive of:

String (Bank)	Max 301 (including 1 auto string) No: 000 - Reference DB not registered and open default string No: 001 - 300: Reference DB comparison registered
Cells	Max 250 cells per string
Test	100 measurements for each cell/battery over its life.

□ Auto Saving

In AUTO REC the measurement data is automatically saved in the internal memory. Maximum of 250 cells' data can be saved in order. The saved data can be transferred to any assigned address in the string record memory or can be removed.

PC Interface - Functional Control through PC













Any of the data stored in the internal memory of the SBS-6500 can be reviewed on the hand held unit directly via the data menu or by connecting the unit to the PC with the supplied USB cable and using the SBS Battery Link Software. All data in the memory can be reviewed, printed or exported via the software interface that comes with the unit. The software also allows direct input of string set-up and programming of the Reference DB while the SBS-6500 is connected to the software.

Back up and restoration of the entire memory is available under the FILE tab in the software. It is recommended that the SBS-6500 memory is backed up after initial programming of the unit, after maintenance activities are completed and prior to sending the unit in for calibration, evaluation or repairs.

The functional controls of the SBS-6500 are mimicked on the software allowing for selection, entry and saving of programming features.

1.4 Description of each part and functions



- ① Impedance, volt input: *Connect plug of the RED test probe.*
- ② Impedance, volt, temperature input: *Connect plug of the BLACK test probe.*
- ③ LCD display.
- ④ HELP 
- ⑤ Power  : *Power ON/OFF*
- ⑥ LCD back light 
- ⑦ Auto/manual ranging 
- ⑧ Up/down/left/right direction function 
- ⑨ Menu key (F1~F4) 
- ⑩ Impedance (internal resistance) key 
- ⑪ Data (DB, record, table, curve) key 
- ⑫ SBS-2003 upload  key
- ⑬ V / A  key
Volt: max DC 300V input. Currents: adapter DC 40A/400A.
- ⑭ Menu  key
- ⑮ Auto record on/off  key
- ⑯ Encoder rotary switch:
Turn clockwise or counterclockwise direction to select the displayed selection items and push down the selected item to set.
- ⑰ DCA input jack
Indirectly connects with DCA current adaptor (for 40A/400A).
- ⑱ USB interface: *PC interface connector.*
- ⑲ AC adaptor input jack: *Connects to the AC power adapter*

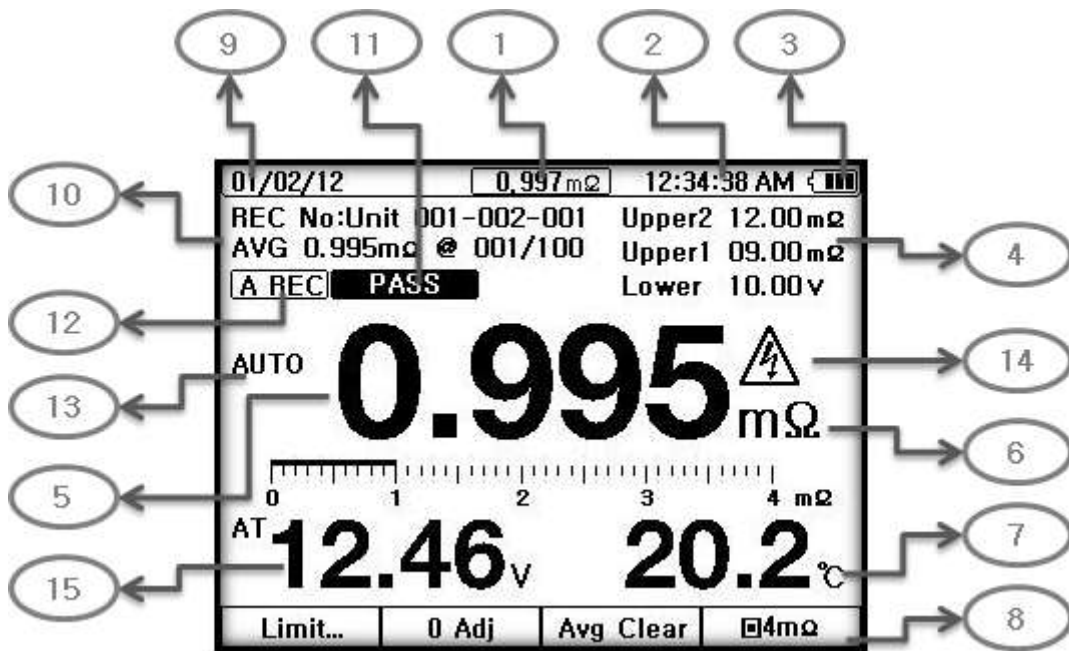

[Display]

- ① Present measurement value in auto record mode
(When measurement in auto hold mode, auto hold data "0.995" is holding at center of display and present measurement data shows "0.997". This data box does not appear if auto hold mode is inactive.)
- ② Measurement date and time
- ③ Battery state of charge/AC adapter indication
- ④ Limit: upper2, upper1, and low voltage warning reference points.
- ⑤ Impedance value display
- ⑥ Unit of measurement
- ⑦ Temperature value display
- ⑧ 4m Ω range key
- ⑨ String-Cell-Test display (REC No:)
- ⑩ Measurement average and number of averaged data
 (Displayed in conjunction with auto hold)
- ⑪ Comparator (pass –warning–fail) indication.

- ⑫ Auto record: When in auto hold, auto record is automatically activated. Readings are saved at the preselected record memory address in order, max of 250 cells.
- ⑬ Auto: auto, manual ranging
- ⑭ Warning sign (safety ratings limits exceeded)
- ⑮ DC voltage measurement

1.5. Dimensions and Weight

Dimensions: 4.2" (W) x 8.3" (H) x 2.2" (D) / 107 mm(W) x 220mm (H) x 55mm(D)

Weight (main unit including battery) : 2.2 lbs / 1.0kg

2. Initial Settings Before Use

2.1. Insert Test Leads

To avoid measurement errors or electrical shock, make sure to insert the test leads into the tester correctly according to the marked polarity. Jacks are pinned to prevent cross connection.

- For safe and accurate measurement of resistance and voltage, only use the battery test leads supplied with the SBS-6500. Replacement test lead sets are available.
- Insert the SCK type plug of test leads into (+) and (-) as shown in the picture below.



[Insert SCK type plug]



[Pin type battery test lead for impedance, voltage, temperature measurement]

Clamp type battery test leads are an optional accessory available.

Part Number: **6500-CLAMP-PROBE**

- Besides measurements for resistance, voltages and temperature, a clamp type high current adapter can be used for indirect measurement of DC Currents in the V/A mode of the SBS-6500.
- DC hi current adapter (CT) for indirect measurement: 40A/400A DC range.
- DC current adapter is an optional accessory.

Part Number: **6500-CURRENT-CLAMP**

2.2. Power ON/OFF

Use the power key on the unit to power the SBS-6500 on or off.

[ON]





- Hold the power key longer than two seconds. The unit will power on with a beep sound.
- After power on, initial display on screen shows manufacturer and firm ware version information momentarily and then changes to measurement function in auto record mode of operation.

[OFF]

- Hold the power key longer than two seconds. The SBS-6500 will power off with beep sound.

2.3. Real Time Clock function

Once the date and time are set, the unit features real time clock stamping. The upper line of the LCD screen displays: month/day/year (left) and hour/minute/second (right).

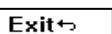
- Press the  key to enter the Menu mode. Select **Date Format** YY/MM/DD or MM/DD/YY.
- If the time is not correct, select **Time** and   to adjust time.
- Set day, month, year, hour, minute, seconds and then press   key to save time settings.

2.4. Back Light Display

- Press  key will toggle the LCD back light on or off.



2.5. String and Reference Set-Up

- Follow the (**SBS-6500 String and Reference Set-Up Guide**) supplied on the disk with the software for setting up all of your battery string locations, entering all of your battery types and setting alarm reference settings.

3. Measurement

For safe and accurate measurements, please read the full manual carefully.

Make sure to pay attention to the following:

- **Do not measure over DC 100V** battery at impedance  measurement range. This is to protect from electric shock.
- **Do not measure over DC 300V** input when measure voltage at  is measurement range. This is to protect from electric shock.
- **Do not measure AC voltages** in either testing mode of the unit.

[Caution]

- Do not exceed the maximum rated voltage or current of each measuring range. Exceeding input ratings may cause damage to the tester.

[Note]

- Internal resistance of the battery being measured can be done with the system charging or on open circuit. Low voltage limits should be adjusted to the condition of the battery at the time the measurements are being made.
- In order to increase accuracy of measurements from one inspection to the next, the measurements should always be taken in the same location. Measurement of batteries directly on the posts will provide more accurate readings. Hardware, washers and lugs all add resistance to the measurement values.
- Ensure the probe pins are clean and free of dirt, dust, etc. prior to taking measurements.

3.1. "0" Point Adjustment before Measurement

- Zeroing out the test leads prior to use ensures that the resistance of the leads themselves is not included in the measurements being taken.

"0" adjustment is required when the unit is first set-up, when switching from one set of test leads to another and periodically to ensure accuracy of readings.

3.2. "0 ADJ" 0 Adjustment Procedure (Resistance Measurements)

In order to get accurate measurement, anytime old test probes are replaced with new ones it is strongly recommend to perform a 0 ADJ before measurements.

- Before measuring impedance, in order to improve accuracy, insert test probes onto the 0 ADJ board (supplied with unit) and conduct a 0 ADJ.
- In the Ω Test function, HOLD the  key for longer than two seconds. Adjustment value to be set to zero and measurement value is displayed.
- Trying to do a 0 ADJ without probes in contact with the 0 ADJ board will cause a fail message to be displayed. Failure to adjust may also indicate a faulty set of test probes.
- The 0 ADJ or 0.0 point of all measurement ranges is automatically adjusted in order.
- Even when the tester power is off, the 0 adjusted values are retained until the next 0 ADJ is conducted.
- 0 ADJ should only be conducted with the 0 ADJ board supplied with tester.

How to Short Test Probes with 0 ADJ Board

1) Pin Type Test Probe

- Use the 0 ADJ board with AC 4-terminal probe type.
- Per the illustration found on the following page, select a pair of holes closest to the distance between battery terminals to be measured and press probe tips into the holes.
- The adjustment board should be away from the SBS-6500 by half the length of the test leads.

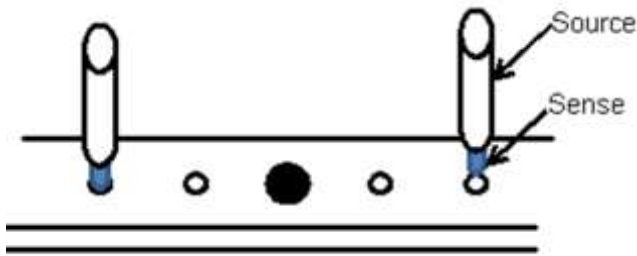

["0" ADJ]

- 0 ADJ requires to fit the tips of the probes down into the holes of 0 ADJ board and press down so that source points of the leads contact the board also.
- Do not place the 0 ADJ board on a battery or metal surface. Adjustment errors may occur from electro magnetic interference.
- If the battery terminal to terminal distance is greater than the distance of the holes on the 0 ADJ board, use the first left hole and last right hole in the adjust kit.

2) Clamp Type Test Probes (clamp type test leads are an optional accessory)



[0 ADJ]

- As shown above, use the adjust kit. Clamp each jaw of test probes onto the adjust kit to conduct the 0 ADJ.

□ Procedure for 0 Adjustment

- ① Connect test probe pins (or clamps) to the 0 ADJ kit.
- ② Hold the F2 0 Adj key for more than 2 seconds.
Test Probes must remain in contact with the 0 ADJ kit

- ☞ If Pins do not contact 0 ADJ kit within ten seconds after **F2** **0 Adj** key is pressed, 0 ADJ will not proceed.
- ☞ When the 0 ADJ value is out of range, the SBS-6500 will display an error message and the adjustment procedure will stop.

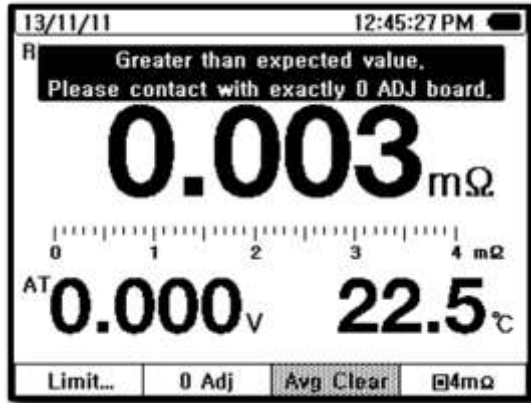

[0 ADJ progress display]

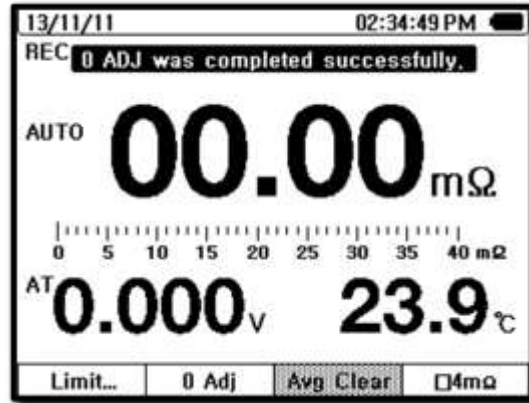

[0 ADJ complete display]

- ③ 0 ADJ is conducted on each range in order.
- ④ When adjustment is completed, a confirmation message is displayed.

During 0 ADJ, an error can occur if the adjustment value is not achieved in normal condition or attains a value above certain level.

- Adjustment value achieved is over 300 counts.
- Test probes are not connected to tester.
- If there is foreign material on 0 ADJ board.
- Passes ten seconds after 0 ADJ started.

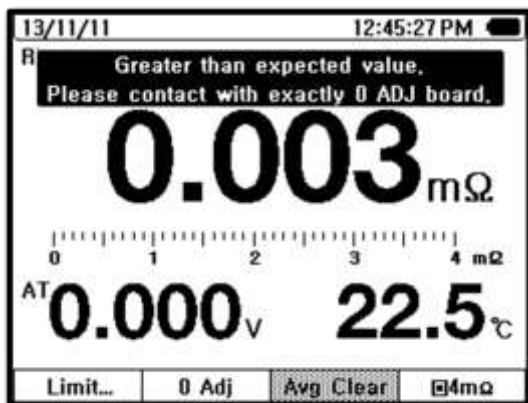

[0 ADJ Error Warning]

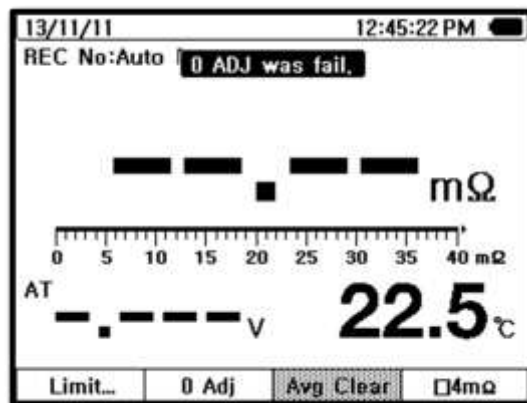

[0 ADJ Error Result]

3.3. Measurements

Resistance measurements operate in auto/manual ranging; voltages operate in auto/manual ranging and current measurements are only manual ranging.

AUTO on the display means auto ranging, no AUTO indicated is manual ranging.

RANGE key operation : To change to manual ranging, press the range key. Each additional press of the key will move the decimal place. To go back to AUTO ranging, hold the range key for longer than two seconds.



1) Resistance Testing

- Pressing the resistance  key, enters the resistance testing mode on the SBS-6500. resistance, voltage and temperature all are measured simultaneously.
- The unit defaults to be in auto ranging (40mΩ- 4 Ω)
- 4mΩ range is active in manual ranging only – press the **F4** **4mΩ** key to change to this range.
- To change the range in manual ranging in 40mΩ- 4 Ω ranges, press the **RANGE** key and change ranges. Each time the key is pressed it changes range (moving the decimal point one place each time).



[Resistance Measurement]

2) Voltage Testing

- Pressing the V/A  key enters the voltage testing mode on the SBS-6500. voltage, current and temperature are measured simultaneously.
- The default is AUTO ranging.
- To change the range to manual ranging, press the  key and change ranges. Each time the key is pressed it changes range (moving the decimal point one place each time). Hold the range key for more than two seconds to return to auto ranging mode.
- In  measurement mode voltage, current and temperature can be measured simultaneously. Auto hold and auto recording are both available in V/A measurement mode. (auto hold – auto record mode)

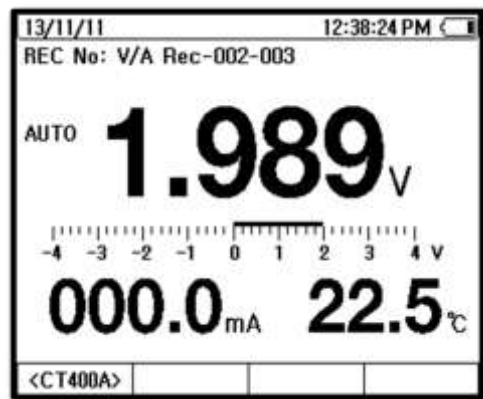

[Voltage Measurement]

3) Current

Current measurement is a subsidiary measurement function in the voltage measurement mode which always set to manual ranging. Use of an optional current clamp is required to measure current.

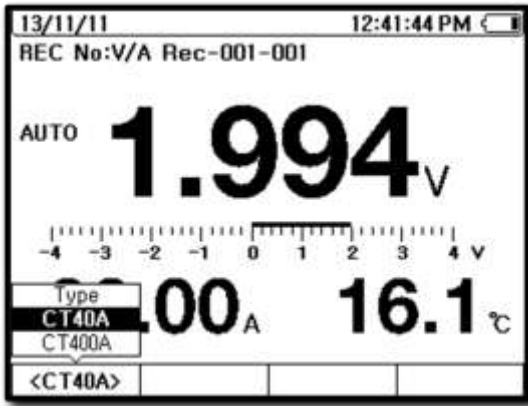

[CT Range selection]

- Pressing  key, allows you to select the external clamp range (CT measurement : DC 40A/400A connect with external DC current adapter). After selecting the type, press the encoder (center rotator key) to complete the setting.



[Currents Measurement]

4) Temperature

Temperature measurements are a subsidiary measurement function in  resistance measurement or  voltage measurement. While measuring resistance or voltage, temperature measurements are recorded from the temperature sensor installed inside of the (-) pin probe or (-) clamp.

Measured temperature indicates battery terminal contact temperature but not the internal battery temperature or electrolyte temperature.

- °F or °C is set-up in the menu (press  key)

3.4. Auto Hold / Record

1) Auto Hold (A Hold)

- Auto hold-auto record mode is the factory default mode. The tester is always in auto hold-auto record mode when the SBS-6500 is first powered on.

Press the  key to enter the no record mode. To return to auto mode, press the key again.

- If auto hold is set,  is displayed near the top left of the LCD screen.
- When measurement data shows "----", auto hold did not activate
- Auto hold and auto record always work together. When auto hold works, the measured data is automatically recorded at the selected record memory location.

- When the next measurement is taken while in auto hold, the auto hold function is restarted.





[Auto Hold]

2) Stop Auto Hold Function

To stop the auto hold function, press the  key.

3) AVG Clear

- In the auto hold function, the AVG (average) feature is automatically activated.
- AVG measurement function calculates AVG value from a multiple of repeated measurements (maximum of 100 measurements) of battery measurement deviations.
- AVG measurement is available only for the main measurement of the unit “Ω” or “V”.
- In impedance (internal resistance) mode, main measurement (main display) “Ω” is the AVG measurement. Sub measurements (sub display) of voltage or temperature are not averaged.
- In voltage mode, voltage will be the AVG measurement. Other sub display measurements cannot be averaged.
- To stop or reset AVG measurement, press   key. Then AVG value is cleared and ready to begin averaging again.

3.5. Judgment of Battery Condition

Battery condition is judged based on measurement data of battery impedance (internal resistance) and voltage when compared to a reference value for that particular make and model of battery when it was new. Each battery manufacturer should provide guidance for reference values to be used for determining replacement criteria.

- Battery reference value. Example: 4mΩ, 1.6V.
- Standard to judge battery condition.
- Impedance:
 - ☞ [WARNING] 5.2mΩ (1.3 times increased from Initial data: 4mΩ). (130% of initial)
 - ☞ [FAIL] 6mΩ (1.5 times increased from Initial data: 4mΩ). (150% of initial)
- Voltage :
 - ☞ [WARNING] Minimum acceptable float voltage or open circuit voltage for the battery / cell –or- (1.44V (90% of initial data: 1.6V) for non-rechargeable cells.

		Ref	Upper1	Upper2
END/V →	Hi	Pass	Warning	Fail
	Lo	Warning	Warning	Fail

150% 200%
 ↓ ↓

[Standard to judge on battery deterioration]

- Battery deterioration can be judged from impedance. Impedance value usually increased by 1.3 to 1.5 times from initial data from a new or good battery. There are differences from each manufacture even for batteries of the same capacity.
- Measurement voltage decreases from initial data from new or good battery due to plate deterioration or sulfation of the plates.
- Impedance and voltage data trends can be used as a reference to judge battery condition and plan replacements in advance prior to system failures.

4. Limit (Comparator)

4.1. Limit judgment function



Compare initial set-up data of the battery when installed and new against the present measurement data of the battery. A three rank rating can be found from the comparison **PASS, WARNING, FAIL** status.

There is an audible alert sounds for a **WARNING or FAIL** status. Also **PASS, WARNING or FAIL** is displayed on the screen as test results are saved to the memory.

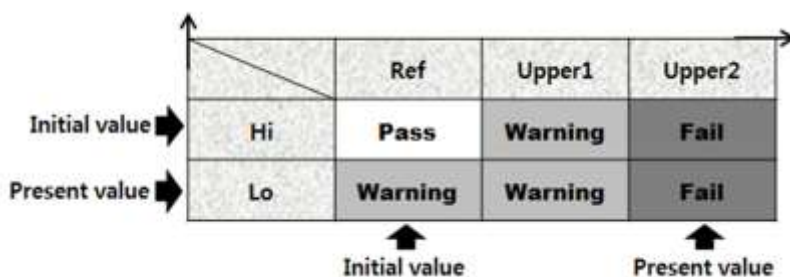
- Impedance: warning level max limit (**WARNING**).
failure level max limit (**FAIL**).
- Voltage: minimum limit (**WARNING**).



[LIMIT setting]

- Press the  key (impedance) and press the  key. The current limit set-up values are displayed. Select  to enable alarms. Press F4 back to return to measuring screen. The limit values will appear on the right of the LCD screen.
- When limits are active the battery measurement results will be identified as pass, warning or fail when stored in the memory table, by audible alert and results displayed on the screen at test end.
- Limit set-up can be accomplished by one of two methods available.
 - ☞ Direct setting method by editing the limit values on the SBS-6500.
 - ☞ Recall an existing reference value set from the Reference DB.
- When there is no present measurement, the main display shows 「---」 and the condition result (pass, warning, fail) is not displayed.

- Low voltage judgment is based on absolute value. Therefore a measurement of reverse polarity of test probes also would be valid. Data is saved as absolute values.

4.2. Limit Function Operation Procedure

1) Limit Function Selection

- ① In impedance measurement mode (Ω), select **F1** **Limit...** key.
- ② At limit setting mode, set-up limit value at **F2** **Recall...** key or **F3** **Edit** key enter the desired values and press **F1** **Limit** to activate.
- ③ Press **F4** **Back** key or Ω key to complete limit setting.
- ④ After setting, mode is switched back to measurement mode. Upper right corner of the LCD screen will show the actual limit value set.
- ⑤ After measurements are completed, the limit function can be released by pressing **F1** **Limit** and press **F4** **Back** key. The limit settings are released and the limit set points disappear from the upper right corner of LCD screen.

2) Direct Input of LIMIT values

- ① In limit setting mode, press **F3** **Edit** key.
- ② Use the direction keys (left/up/down/right) and encoder switch to set limit values.
- ③ After values are set, press **F1** **Limit** key to activate the new settings.
- ④ After setting or selection is done, press the **F4** **Back** key to convert to measurement mode.
- ⑤ On measurement screen. Limit values are displayed in upper right of LCD screen.







[limit display]

3) Selecting an Existing Entry from the Reference DB (Recall)

Recall an entry from the DB in the tester and use it to set limit values.

Desired DB entry can be selected by using the up/down  keys or encoder switch.

- ① At limit set-up mode, press  to open the Reference DB.
- ② Select desired DB by using up/down  key or encoder switch.
- ③ After DB entry is selected, press the  key to activate.
- ④ When the set-up or selection is complete, press the  key or encoder switch to return to the measurement mode.

4.3. Judgment of Limit

- ☞ Measurements will be compared to the three programmable reference value alarm thresholds. Based on the actual measurements, the Pass, Warning, or Fail status will be displayed on the LCD, signaled by audible alerts and stored in the memory along with the data from the measurements.

[How Results are Determined]

- If the measured value of resistance is lower than warning level limit, and if voltage measured simultaneously is higher than minimum limit then the condition is a **Pass**.
- If the voltage measured is lower than minimum limit then the condition is a **Warning** with an audible alert.
- If the measured value of resistance is higher than warning limit and lower than failure limit or if voltage measured simultaneously is higher or lower than minimum V limit, both cases the condition is a **Warning** with an audible alert.
- If the measured value of resistance is higher than failure limit and if the voltage measured simultaneously is higher or lower than minimum V limit, both cases the condition is a **Failure** with an audible alert.

4.4. Limit Function – Audible Tones

When the condition of the battery is determined and the reading is recorded, the SBS-6500 will emit an audible alert to indicate the condition. Audible alerts are distinguished enough to note pass, warning or fail indication.

Judge Result	Beeper Sound
PASS	After judgment, sounds 1 time for short time(100ms).
WARNING	After judgment, sounds 2 times shortly(each 150ms).
FAIL	After judgment, sounds 1 time for long.(400ms)

4.5. Release Limit Function

To release the limit (comparison) function, in limit set-up mode, select **F1** **Limit** to stop the limit mode.

2. Data DATA

Management and analysis of the stored data in the SBS-6500 Battery Resistance Tester.

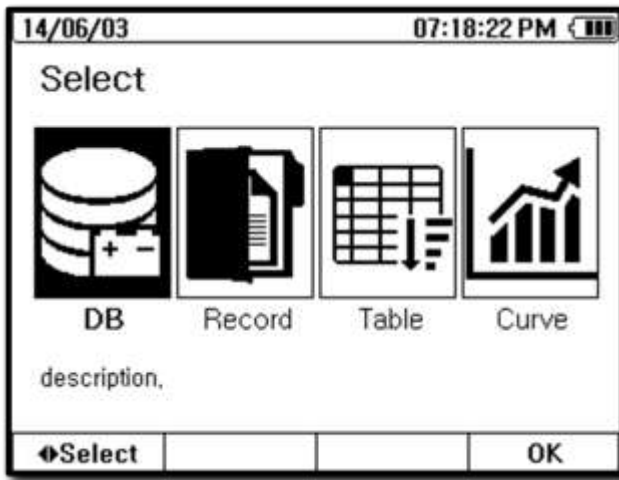

[Data display]

DB (Data Base)

- Add, delete or recall reference data

Record

- Select and set address of string-cell-test number
- Add or delete battery strings
- View or recall recorded measurement data
- Erase, copy and/or paste recorded measurement data from one location to another in the internal memory

Table

- View the history record of strings in the table
- View the history of recordings for single cell
- View the history or records for all cells in the string for the same measurement test

Curve

- Displays a graph of the history of a specific cell over its history

6. Data - Data Base (DB) DATA

Data base is the referenced data library (initial data) for battery management which is used for comparison and analyzing battery performance against known reference values.

Reference data in the data base is saved by battery model and manufacturer: Data includes battery type, capacity, cell/battery voltage, reference impedance value and alarm limits.

Reference data saved in the data base can be used for comparison limit set-up and determination of the condition of the batteries.

14/10/22		04:24:06 PM	
DB No. 001/200			
STT2V150			
SBS			
Lead-acid	165.0Ah		
Type	Capacity		
2.000v	2.190v	1 Cells	
Measurement Voltage	Low Voltage	Cells / JAR	
1.150ma	1.496ma	1.726ma	
Impedance	Warning	Failure	
Select	Edit..	Erase	Exit↵

[Data base display]

- Press DATA key to enter DATA display screen.
- Press ◀▶ key to select DB. Press F4 OK to enter DB mode.
- To view the DB entries, use the ▲▼ keys or encoder switch. DB address numbers and data displayed simultaneously.
- Press F1 Select to set the current DB entry as reference data and limits are automatically set-up.
- The SBS-6500 will automatically return to the impedance measuring mode ready to take readings.

6.1. Data Base Entries

[Information that is stored in the DB entry]

- DB No (???) / 200 Up to 200 reference values can be programmed and stored.
- Battery Voltage Nominal voltage of the cell measurement interval.
- Capacity Rated AH capacity of that battery model
- Impedance Reference impedance values for that battery model
- Model Number Specific model of battery or cell
- Maker Manufacturer's name for reference

6.2. Data Base Functionality





- Prior to measurement, recall one of the reference data entries saved in the DB and use as battery comparison information for testing.
- Use the limit feature on the measurement screen to select the desired reference value from the DB, press **F2** RECALL key to automatically open the DB mode and select the desired DB entry as reference data by using **▲** **▼** keys. This changes the alarm thresholds to the new reference value.
- The selected DB entry battery information is used in the generation of reports and history of measurements for that string of batteries.

6.3. Entry and Deletion of DB Entries







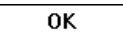

Input, editing or deletion of DB entries can be done directly on the SBS-6500 or through the SBS Battery Link PC Program.

[Input a New DB Entry]

- Press **DATA** key to enter data display screen.
- Press **◀** **▶** key to select DB. Press **F4** **OK** to enter DB mode.
- Use **▲** key to scroll through the reference entries to the next blank entry.
- Press **F2** **New Unit...** key to open the new DB entry page display screen.

- The cursor points to the "User ???". This will be the battery model.
- Press  EDIT key to open keyboard. Enter the battery model name. Press F4 OK to save the information.
- Use   key to cursor move to the other properties for that entry.
- Press  EDIT key to edit each property. All entries must be modified to save the entry.
- After editing, press   key to save the new DB entry. If the OK key is grayed out, there is an error or blank in the entry that needs to be corrected.
- New DB entry is displayed in the list of DB entries.

[Functions of the SBS-6500 Built in Keyboard]

-   Left right arrow keys will select the cursor position.
- Rotate  key to select the desired character.
- Press  key to input the selected character.
- Pressing the  key will switch between lower case, upper case, numeric and symbol keyboards.
- Press  key to insert a space.
- Press  key to delete character.
- Press  key to save the entry and close keyboard.

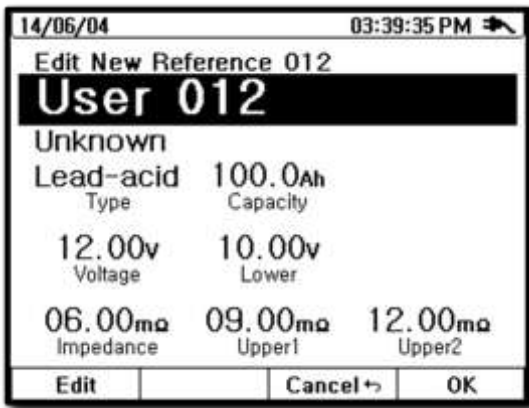

[New DB]

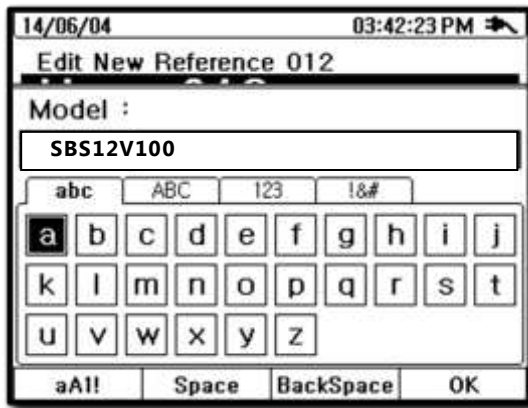

[New DB: Edit Model Name]

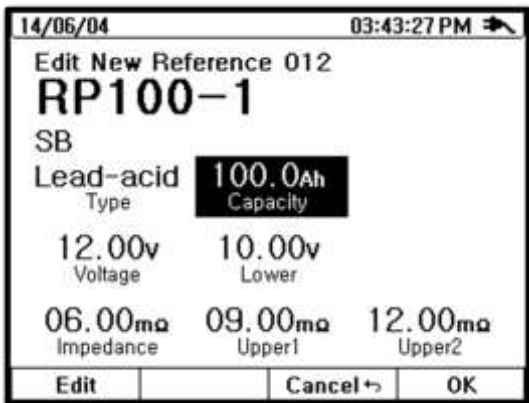

[New DB: Edit Cursor]



[New DB: Edit Property]

[DB Entries from the SBS Battery Link Software]

- Load SBS Battery Link Software program on your computer.
- Connect the SBS-6500 (mini USB port) to the computer with USB cable.
- Run the SBS Battery Link Software by clicking on its desktop icon. The SBS-6500 will automatically connect to the software as soon as the unit is connected and powered on.
- Click on the Reference DB tab in the data view box (right hand portion of the window).
- Enter all of the battery information and measurement limit information into the boxes.
- When all of the information is correct, click the ADD key.
 - ☞ When a new DB entry is created, the DB number is automatically assigned to it.
 - ☞ Select a DB entry from the list, modify the information and click the SAVE key to edit an existing entry.

- Select a DB entry from the list, click the DELETE key to remove an existing entry.
- ***For DB entries which are referenced by a string name in the string list can be modified but not deleted.
- ***For DB entries which are modified, the new saved values are applied to all strings that use that DB entry as its reference value.

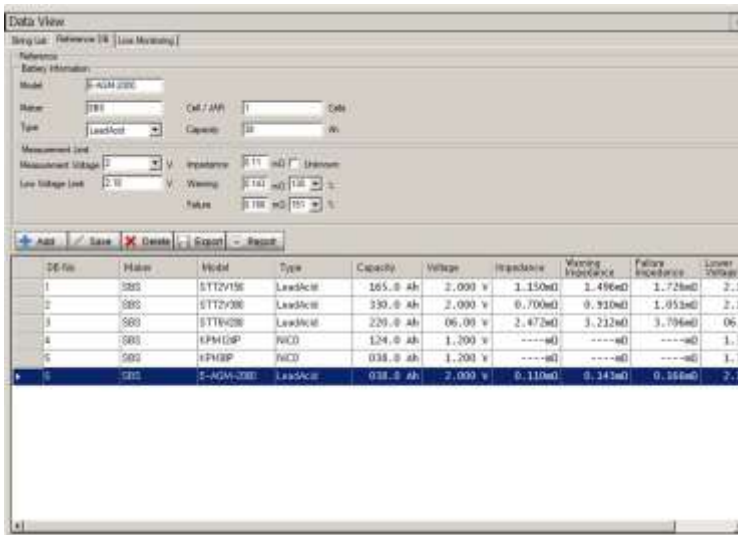

[Data Base Input Display]



- ADD – Saves all entered data as a new entry in the DB and assigns next open DB number.
- SAVE – Saves changes made to an existing DB entry and applies to all strings.
- DELETE – Removes a DB entry from the Reference DB (not available if reference is in use).
- EXPORT – Creates an Excel report of all the reference values current programmed in the DB.
- REPORT – Creates a report for printing of all the reference values currently in the DB.

7. Data – Recording Function DATA

7.1. Record Function

Save the measured data to a specific string in the internal memory or recall the saved data. Press **DATA** key, then select RECORD.

Saved data includes date, hour, resistance value, voltage value, temperature, specific gravity (SBS-2003 upload), comparator limit values and test results.

Saved data can be recalled and reviewed on the SBS-6500.

Saved data can be viewed with the SBS Battery Link Software on the computer or used to create reports, export data to Excel, create charts of cell or string history.

7.2. Record Memory Matrix

Built in high capacity memory can contain up to a maximum of 301 strings of data.

There is a maximum of 301 Strings (including 1 auto string No: 000 - Reference DB not registered and Strings No: 001 ~ 300: referenced to DB reference assignments).

Each string can hold up to a maximum of 250 cells. Each individual cell (battery) has 100 data (test) result blocks to store readings in. There is a 25 year history of cell readings for every cell in every string.

Unit	Cell	Address						
Open Unit	Cell001	001	002	003	..	098	099	100
	..	001	002	003	..	098	099	100
	Cell250	001	002	003	..	098	099	100
String 001	Cell001	001	002	003	..	098	099	100
	..	001	002	003	..	098	099	100
	Cell250	001	002	003	..	098	099	100
..	..	001	002	003	..	098	099	100
String 301	Cell001	001	002	003	..	098	099	100
	Cell250	001	002	003	..	098	099	100

1) String List (Banks)

Each string designated in the string list is a series of cells of batteries which makes up a complete battery system. As an example, 60 cells of flooded lead acid batteries connected in series would be a complete battery string.

All batteries in the string should be of the same manufacturer, model and age. Mixing of types, models and ages can lead to significant problems for both the new and old batteries. Each string that is set-up will be referenced to an entry in the Reference DB list for alarm parameters.

When measuring cells for a system that is not already set-up in the string list the open string (000) can be used to record the measurements. Later, all the data in that test block can be copied and pasted into the correct location in the data table.

Meter mode (voltage, current, temp) measurements via the  key function can be recorded at only in the open string memory spaces.

2) Cell (Battery)

Each battery system or string consists of a number of cells/batteries connected together in series.

Within a string, each cell can be measured up to a maximum of 100 times over the history of the battery.

When the unit is operated with  Auto Record is on. The cell number is automatically advanced by one each time a reading is taken and the results are recorded in the order they are taken in that test number memory location.

7.3. Record Display

Press encoder switch to call the string index list.

Use up/down/ direction keys on the SBS-6500 to select the record address.

Test number on the display is equal the number of tests performed on that specific string of cells for selected string.

Width of the chart is the test number (001 ~100) of each cell. Length of the chart is the cell numbers (001~250).

Data recorded space blocks indicate condition results (**P**: Pass, **W**: Warning, **F**: Fail, **G**: Gravity Only, **O**: No Assigned Reference). A blank space indicates no data is stored in that location.

When you select a string, the reference data for the string appears at the bottom.

Move the cursor to select the block where you want to begin storing readings and press the F1 "Start" key to enter the resistance measuring mode.

13/11/11		02:42:21 PM							
↓ 001 Unit 1									
	065	066	067	068	069	070	071	072	073
Cell 001	P	P	P	P	P	P	P	P	
Cell 002	P	P	P	P	W	W	W	W	
Cell 003	P	W	W	W	W	W	W	W	
Cell 004	W	W	W	W	F	F	F	F	
Cell 005	P	P	P	P	W	W	W	W	
Cell 006	P	P	P	W	P	W	W	W	
Cell 007	W	W	W	W	W	W	W	W	
Cell 008	W	W	W	W	W	W	W	F	
Roket RP100-1 Lead-acid 100,0AH									
12,00V (10,00V) 06,00mΩ (09,00mΩ/12,00mΩ)									
08,41mΩ 12,01V 019,6°C 14/01/18 10:12:56 PM									
Start	Replay...	Manage↕	Exit↵						

7.4. String Set-Up

String list is the identification of a battery system that records are going to be saved in.

[String Addition on the SBS-6500]



- ① Press **DATA** key to enter data display screen.
- ② Press **◀ ▶** key to select "Record" and press **F4** **OK** to enter.
- ③ Use **▲ ▼** key to move to vacant string number.
- ④ Press the **F2** **New Unit...** key to open the new string entry screen
- ⑤ The cursor highlights the string name (default value is Unit ###).
- ⑥ Press the **F2** **EDIT** key to open the keyboard. Then enter a unique string name to identify the battery system and location where the readings will be taken.
- ⑦ Use **▲ ▼** key to cursor move to REF DB..
- ⑧ Use **◀ ▶** keys or rotary selector to select reference data from DB that you want to use as the alarm set points for that string.

Press the **F3** **OK** key to save the new string set-up.

- ⑨ Pressing the F2 "Edit" key while a string name is highlighted will allow you to edit the string information or Reference DB assigned right from the SBS-6500.
- ⑩ The newly created string name is added to the list of strings.

*** Addition of strings and reference value assignment can also be set-up by connecting the SBS-6500 to the SBS Battery Link Software on the PC.

[How to Input Using Keyboard]

- Use the arrow keys to move cursor position.
- Rotate  key to select character you want.
- Press  key to Input selected character.
- Pressing the **F1** key will be switch between keyboards.
- Lower case, upper case, number, special characters.
- Pressing the **F2** key will insert a space.
- Pressing the **F3** key will delete a character.
- Pressing the **F4** key will save the changes and close the keyboard.

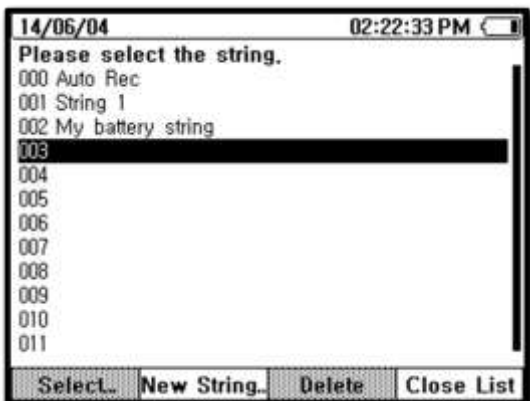

[New Unit Number selection]

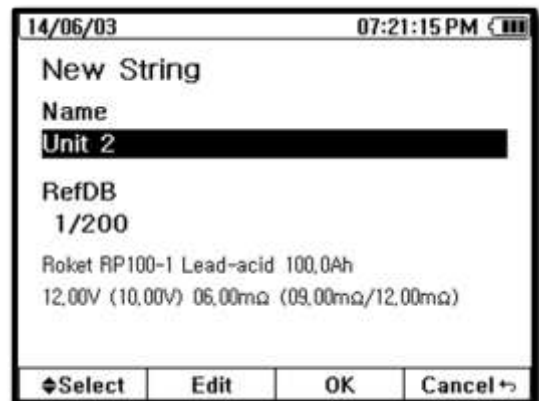

[New Unit Display]



[Input String Name]

7.5. Recording Address Selection.

[Address Set-Up Procedure]

- ① Press the **DATA** key to enter data display screen.
- ② Press **◀ ▶** key to select RECORD then press **F4** **OK** to enter.
- ③ Select string and address by **▲ ▼** direction keys or encoder switch.
- ④ After selection of the string, the data table for that string will open up. Move the cursor to the location you want to record your readings and press the **F1** **Start** key to complete the settings and return to resistance measuring mode. When operating in auto record mode, the data will automatically recorded in the next open test number slot.

[NOTE]

When recording, please follow the above procedure.

- If the selected address already contains data, it will ask whether to use the next address or overwrite the data already existing in that address.
- If readings are taken without selecting an address, the data readings are recorded in the temporary address (000) which operates in auto record. These readings can be copied to a permanent location at a later date and time.

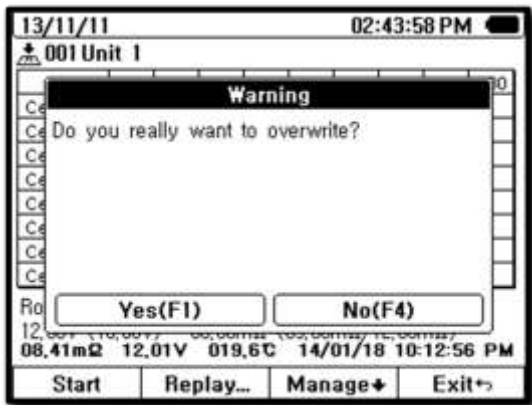

[Overwrite Saving]

7.6. A-REC (Auto Recording)

“**Auto recording**” function can transfer the measured data and automatically store in series simultaneously when measure the data.

[Operation Method and Procedure]

1) Auto Recording Operational Principles

- Auto Recording is active as long as the **[A REC]** symbol is on the LCD screen.
- Measured readings are automatically recorded in the memory to the address which is displayed following the REC NO above the **[A REC]** symbol.
- Recorded data is stored in sequence of input. All cells/batteries are recorded in a string test location in cell number order. Test numbers are consecutive from one date to the next test date. When you fill up the record maximum memory space of 100 tests, the memory switches to first in/first out mode, stored data will be removed from first stored data and second stored data as # 101 data and # 102 data are saved in the memory.

7.7. Review of Recorded Data

Recall any recoded data from memory and replay the data.

[Operation Procedure]

- ① Press **DATA** key to enter data display screen.
- ② Press **◀▶** key to select "Record" then press **F4** **OK** to enter.
- ③ Select the string you want to review the data in.
- ④ Select the data from recorded data address by **◀▶▲▼** direction key or ENCODER key. Then press **F2** **Replay...** key to view the recorded data on display.
- ⑤ When in replay mode, the record data with record number is displayed on the LCD screen.
- ⑥ To view data of another table entry, press **F1** **Back↔** which will take you back to the table and you can select another data block.
- ⑦ Press **F4** **Back↔** to exit from the replay function.

[NOTE]

- Selected memory block data is displayed at the bottom of the screen without going into replay.
- Condition of the cell/battery is displayed by the symbol in the data block table (P,W,F,G). A blank box indicates no data is stored in that location.

[Replay LCD screen]

- Upper center of screen shows **Replay** Replay.
- Record number of replay data shows at upper left of screen.

13/11/11		02:42:21 PM							
001 String 1									
	065	066	067	068	069	070	071	072	073
Cell 001	P	P	P	P	P	P	P	P	P
Cell 002	P	P	P	P	W	W	W	W	W
Cell 003	P	W	W	W	W	W	W	W	W
Cell 004	W	W	W	W	F	F	F	F	
Cell 005	P	P	P	P	W	W	W	W	
Cell 006	P	P	P	W	P	W	W	W	
Cell 007	W	W	W	W	W	W	W	W	
Cell 008	W	W	W	W	W	W	W	F	

Roket RP100-1 Lead-acid 100,0AH
 12,00V (10,00V) 06,00mΩ (09,00mΩ/12,00mΩ)
 08,41mΩ 12,01V 019,6°C 14/01/18 10:12:56 PM

Start Replay... Manage+ Exit↵

[Replay Select]

14/06/04		Replay		02:27:51 PM	
REC No:String 001-001-072					
AVG ----- @ 000/100					
[A REC]		[WARNING]			
AUTO		11.07 mΩ			
0 5 10 15 20 25 30 35 40 mΩ					
AT		12.07 V		19.7 °C	
Back↵					

[Replay Screen]

7.8. Erase of Recorded Data

[Operation Procedure]

- ① Press **[DATA]** key to enter data display screen.
- ② Press **[←] [→]** key to select RECORD then press **[F4] [OK]** to enter.
- ③ Select the string from the list where you want to erase data from and press **[F1] [SELECT]** key.
- ④ Press the **[F3] [Manage+]** key.
- ⑤ Select the data block to erase from recorded data address by using the arrow **[←] [↑] [↓] [→]** directional keys.
- ⑥ After address is selected, press **[F3] [Erase]** key to erase the data.
- ⑦ Pressing the **[F3] [Erase]** key a single time will erase only that data block. To erase the whole string record, hold down the key for longer than two seconds. A pop-up widow will open and ask for confirmation before the whole string is erased from memory.
- ⑧ Press **[F4] [Back↵]** to exit from the erase function.
- ⑨ A single erased block can be restored by hitting the **[F3] [UNDO]** key.

14/06/04		02:30:43 PM									
001 String 1											
	065	066	067	068	069	070	071	072	073		
Cell 001	W	P	W	W	W	W	W	W	W		
Cell 002	W	W	W	W	W	W	W	F			
Cell 003	P	P	P	P	P	P	P	P			
Cell 004	P	P	P	P	P	P	P	P			
Cell 005	P	P	P	P	P	P	P	W			
Cell 006	P	P	P	P	W	W	W	W			
Cell 007	W	W	W	W	W	W	F	F			
Cell 008	W	W	W	W	W	W	W	W			

Roket RP100-1 Lead-acid 100,0Ah
 12,00V (10,00V) 06,00mΩ (09,00mΩ/12,00mΩ)
 11,07mΩ 12,07V 1,178 019,7C 14/08/22

Copy Paste Erase Back↵

14/06/04		02:30:49 PM									
001 String 1											
	065	066	067	068	069	070	071	072	073		
Cell 001	W	P	W	W	W	W	W	W			
Cell 002	W	W	W	W	W	W	W	F			
Cell 003	P	P	P	P	P	P	P	P			
Cell 004	P	P	P	P	P	P	P	P			
Cell 005	P	P	P	P	P	P	P	W			
Cell 006	P	P	P	P	W	W	W	W			
Cell 007	W	W	W	W	W	W	F	F			
Cell 008	W	W	W	W	W	W	W	W			

Roket RP100-1 Lead-acid 100,0Ah
 12,00V (10,00V) 06,00mΩ (09,00mΩ/12,00mΩ)

Copy Paste Undo Back↵

7.9. How to Input Reference (Initial) Data

Each battery's reference values could vary from the next. Reference data is available by contacting the battery manufacturer or sales representative. In the event reference numbers are not available, a check box has been added to the reference value entry screen to disable resistance reading limits and alarms until a known reference value can be obtained or determined. Original installation average value can be used as a reference value, as well.

Reference data should be input into the DB in the SBS-6500 in advance of its use. The measurement data compiled over the history of maintenance on the battery will be recorded and accumulated in the memory of the SBS-6500 to create battery trend comparison curves based on the reference (initial) data and provide information of battery condition judgment (battery health).

1) How to Input Reference Values from the SBS Battery Link PC Program

[Procedure]

- ① Install the SBS Battery Link Software on the PC and connect the SBS-6500 to the PC with the supplied USB cable.
- ② Launch the software by clicking on its desktop icon. Turn on the SBS-6500 and it will sync with the software.
- ③ Select the Reference DB tab in the data view portion of the screen.
- ④ Input all of the reference data for the new battery you are going to create a reference for.

- ⑤ Press the ADD key to store the new reference value.
- ⑥ Each change made to the Reference DB or the string list will automatically be updated on the SBS-6500 as the changes are made.

2) String Information Entry Procedure from the SBS Battery Link PC Program

Enter the name(s) of battery system(s) and assign pre-programmed reference values from the reference DB.

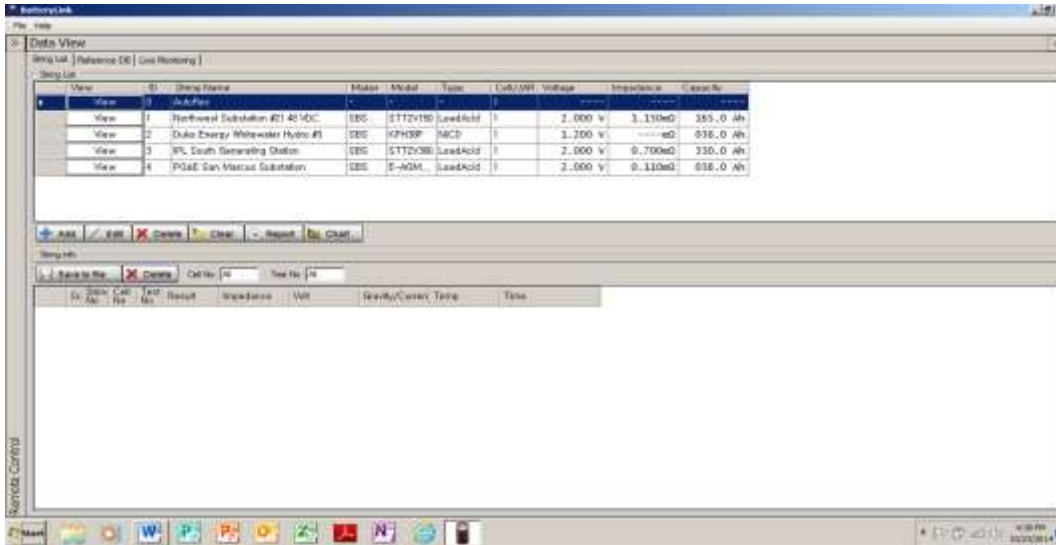

[Unit Information Input]

[Input through PC Software]

- ① Click "String List" tab on SBS Battery Link software window.
- ② Press the ADD key.
- ③ Input location information and select a DB reference value from the drop down arrow.
- ④ Press the ENTER check mark key to the right side the entry line.
- ⑤ New string information is added in the next open ID assignment and updated on the SBS-6500 at the same time.

7.10. Copy and Paste of Recorded Data

Move a single reading or string of readings from the auto record location (000) to a specific string location in the memory for permanent storage.

[Copy and Paste Procedure]

- ① Press the DATA key and select record. Highlight the auto record line and press the F1 SELECT key to enter the data chart for auto record.
- ② Press the **F3** **Manage** key to bring up the complete data table for auto record.
- ③ Move the cursor to the position of the data that you want to move to another location.
- ④ Press **F1** **Copy** key to select a single data entry or hold down the **F1** **Copy** key to select the entire string of data.
- ⑤ Press **F4** **Back** key to return to previous screen string list and select the string where you want to copy the data to.
- ⑥ Select the save address by using the **Left**, **Up**, **Down**, **Right** keys to highlight the block where you want the paste operation to begin inserting the data.
- ⑦ Press the **F3** **Manage** key to open the copy paste sub menu.
- ⑧ Select **F2** **Paste** key to move data to its new location. A status bar will appear as the data is moved to the data blocks.
- ⑨ Press **F4** **Back** key to return to previous display or press any major function key to return to that measurement mode.

14/06/04 02:32:02 PM

001 String 1 Record was copied.

	065	066	067	068	069	070	071	072	073
Cell 001	W	P	W	W	W	W	W	W	
Cell 002	W	W	W	W	W	W	W	F	
Cell 003	P	P	P	P	P	P	P	P	
Cell 004	P	P	P	P	P	P	P	P	
Cell 005	P	P	P	P	P	P	P	W	
Cell 006	P	P	P	P	W	W	W	W	
Cell 007	W	W	W	W	W	W	F	F	
Cell 008	W	W	W	W	W	W	W	W	

Roket RP100-1 Lead-acid 100.0Ah
 12.00V (10.00V) 06.00mA (09.00mA/12.00mA)
 11.07mΩ 12.07V 1.178 019.7C 14/08/22

Copy Paste Erase Back

[Record Data Copy]

14/06/04 02:32:10 PM

001 String 1 Record was pasted.

	065	066	067	068	069	070	071	072	073
Cell 001	W	P	W	W	W	W	W	W	W
Cell 002	W	W	W	W	W	W	W	F	
Cell 003	P	P	P	P	P	P	P	P	
Cell 004	P	P	P	P	P	P	P	P	
Cell 005	P	P	P	P	P	P	P	W	
Cell 006	P	P	P	P	W	W	W	W	
Cell 007	W	W	W	W	W	W	F	F	
Cell 008	W	W	W	W	W	W	W	W	

Roket RP100-1 Lead-acid 100.0Ah
 12.00V (10.00V) 06.00mA (09.00mA/12.00mA)
 11.07mΩ 12.07V 1.178 019.7C 14/08/22

Copy Paste Erase Back

[Data Paste]

8. Data- Table DATA

Built in analysis function is very specialized and independent tool to allow you to view the data.

This feature allows you to explore the history archive of the memory, view test results of a string or cell's history from beginning of life to latest measurement.

8.1. Recall

[Operation Procedure]

- ① Press DATA key to enter data display screen.
- ② Press ◀▶ key to select table or curve.
 - ☞ Table: recoded data is displayed in table format
 - ☞ Curve: trend curve of cell condition is displayed over the history of saved readings.
- ③ Press F4 OK to enter.
- ④ String list displayed on the screen, select desired string to analyze by using the directional ▲▼ keys and pressing F1 Select.. key to enter that string.
- ⑤ Press F1 Select.. key to select the data type you want to view (test number or cell number). Test will bring up all of the results for all the cells of that specific test, where cell will bring up all the stored readings for a specific cell from that string.
- ⑥ In table, press F2 data table and the saved data is displayed in a table format. In curve, press F3 trace, and a trend curve of battery condition is displayed.

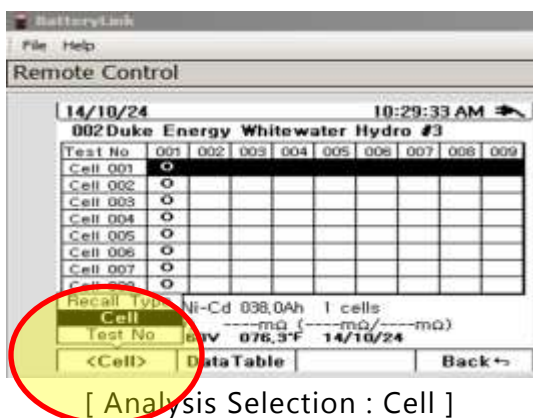

If want to see all of the measurement records for an entire of string of batteries at a specific measurement time, select Test NO. and the highlight bar will change to a vertical bar and allow selection of each test number.

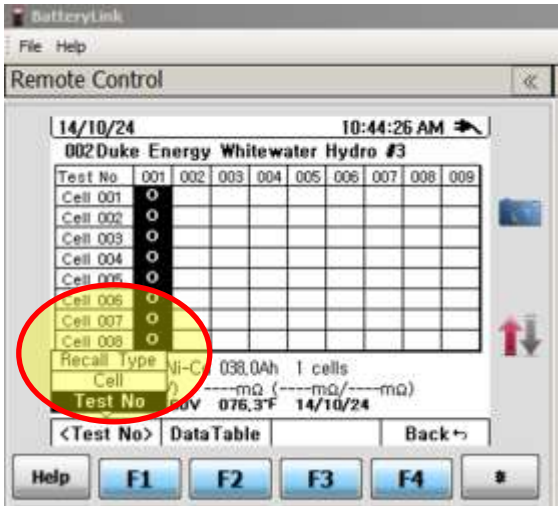

[Analysis selection: Test No]

8.2. Table

Displays saved measurement data in a table format.

☐ Cell Display

The data is displayed in the reversed order of test number with the most current reading being at the top of the list. This allows you to review the trend of a single cell over the history of the readings for that specific cell number.

☐ Test No. Display

This displays all of the results for every cell for a specific test number.

This view allows you to compare all of the readings of the cells within a single string and measurement period for comparison to each other.

It also allows you to identify cells within the string that are significantly different from others of the same type, age and operational history.

□ Battery Condition Sort Order

Table results can be sorted by order of the impedance data, voltage data or measurement test time.

1) Cell

Accumulated measurement data of an individual cell can be sorted in order from highest to the lowest impedance value, from lowest voltage to highest voltage value, or from the latest measurement test to the oldest test number.



[Data Table Display Order Selection]

2) Test No.

Accumulated measurement data of all the cells in the string are measured at the same time are displayed for comparison. The cells can be sorted in order from highest impedance cell to lowest impedance cell, from lowest voltage cell to highest voltage cell or from date and time stamp of the cell data.



[Condition Order Table: Cell number]















9. Data – Curve

9.1. Curve (Trend Curve Analysis)

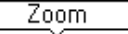
Impedance and voltage measurement data for a cell are displayed in curved line which allows you to observe the trend of the changes over the history of a cell.

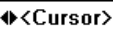
The impedance, voltage and temperature line thicknesses are displayed differently for easy recognition between plot lines.

[Operation Procedure]

- ① Press  key to enter data display screen.
- ② Use the   keys to select curve.
- ③ Press the   keys to enter.
- ④ Highlight the desired string and press   STRING key.
- ⑤ Highlight the desired cell and press  to enter curve mode.
- ⑥ Select soft key menu       as needed.
- ⑦ To exit from curve mode to previous mode, press  exit key to select another cell or continue pressing the  EXIT key to go back to the main data menu.

[Note]

The Number of plotting dots (displayed in a line) is a maximum 100 data points per cell.

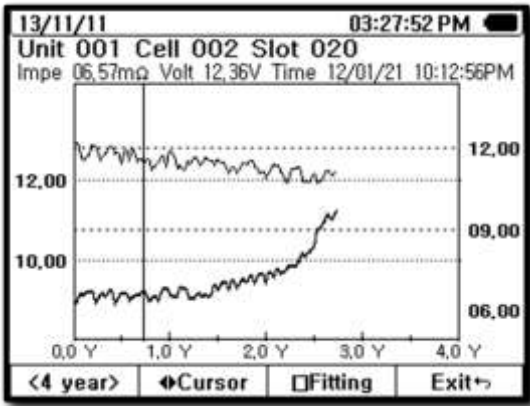

[TRACE Display]

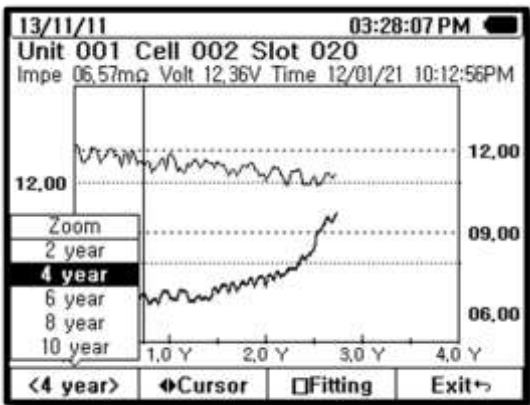

[TRACE Zoom : X Axis 4 year]



[TRACE Zoom : X Axis 8 year]















X-axis indicates time. Y-axis is the curve of the value changes according to impedance and voltage measurement data stored in the memory for that cell.

10. SBS-2003 Digital Hydrometer SG Upload

The SBS-6500 has been designed to merge specific gravity readings from the battery cells taken with the SBS-2003 Digital Hydrometer into the data blocks along with resistance, voltage and temperature data. This allows for a single report to be generated with all maintenance data in place.

10.1 Transfer Specific Gravity Data (SBS-2003 Required)

[Operation Procedure]

- ① Press the  key to enter the SG Upload display screen.
- ② Follow the on screen instructions to prepare transfer of data from the SBS-2003.
- ③ Once the SND command is entered on the SBS-2003 and the (- - -) begins to scroll across the screen, press the  NEXT key on the SBS-6500.
- ④ The SBS-6500 and SBS-2003 will automatically pair and transmit all of the readings stored in the memory of the SBS-2003 (maximum of 250 readings into a string).
- ⑤ Once the devices begin data transfer, progress information will appear on both units as data is transmitted.
- ⑥ Press the   keys to select the first number of the group of specific gravity readings that needs to be copied.
Then press the  NEXT key.
- ⑦ Press the   keys to select the last number of the group of specific gravity readings that needs to be copied.
Then press the  NEXT key.
- ⑧ The string list will be automatically displayed. Use the   keys to select destination string where you want to copy the specific gravity readings into. NOTE: voltage and resistance readings must be in the blocks in order to import specific gravity readings.
Then press the  NEXT key.
- ⑨ Test numbers of then string are displayed.
Press the   keys to select destination test number.
Then press the  NEXT key.

- ⑩ A preview of the merged data is displayed.
Press the $\left[\blacktriangle \right]$ $\left[\blacktriangledown \right]$ keys to select destination cell for the first specific gravity reading. Then press the $\left[F3 \right]$ NEXT key.
- ⑪ The SBS-6500 will paste the specific gravity readings into the data blocks in order beginning with the block selected in the step above.
- ⑫ Press the $\left[F4 \right]$ EXIT key.

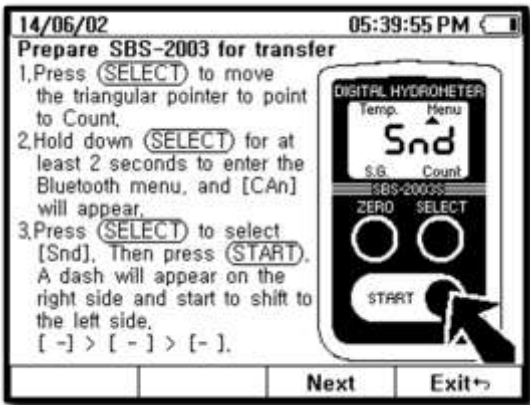

[Data Transfer: Initiate]

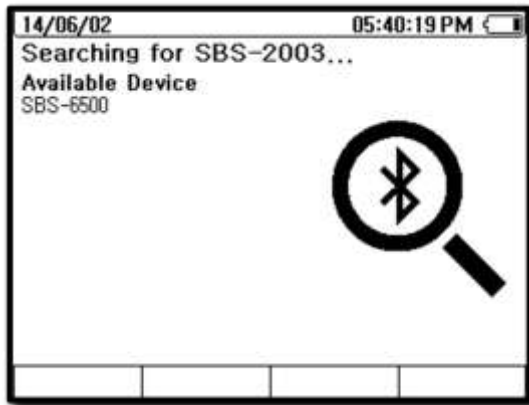

[Data Transfer: Searching]

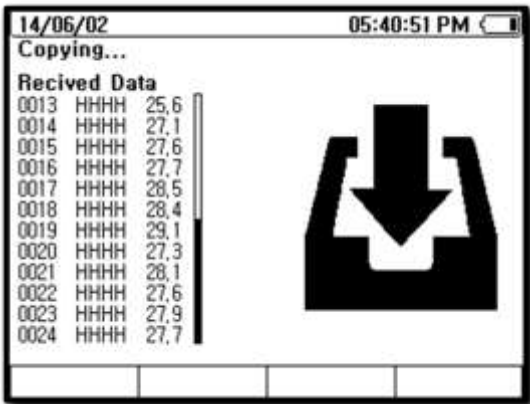

[Data Transfer: Upload]

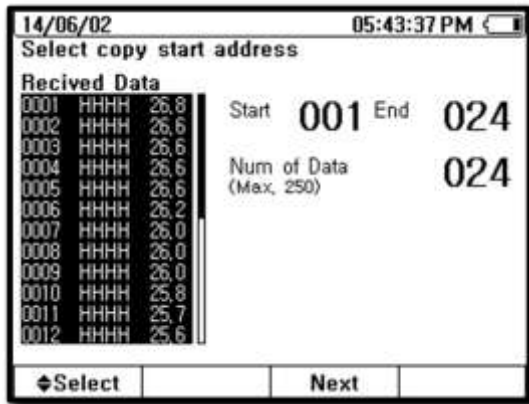

[Data Transfer: Select readings]

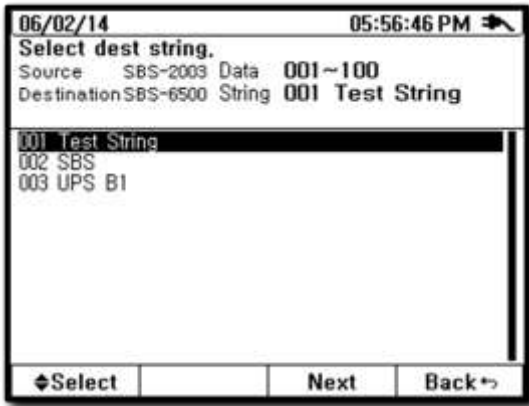

[Data Tranfer: Select string]

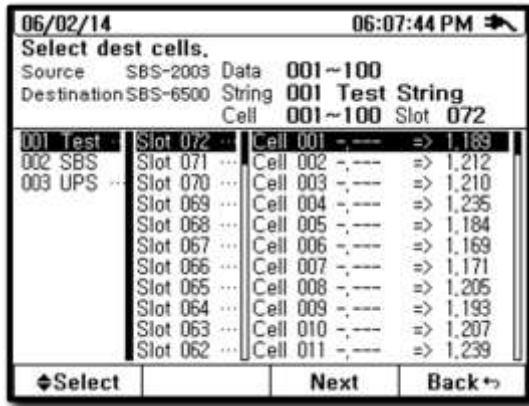

[Data Tranfer: Preview merge]

11. Auxiliary Functions

11.1. Auto Power Off

The auto power off function is active only when the unit is operating on the internal rechargeable battery. The function is disabled any time the SBS-6500 is powered through AC power adapter.

During periods of inactivity, the auto power off feature will turn power off to the SBS-6500 to save capacity of the battery. Turning the unit back on will return it to the mode the unit powered off in.



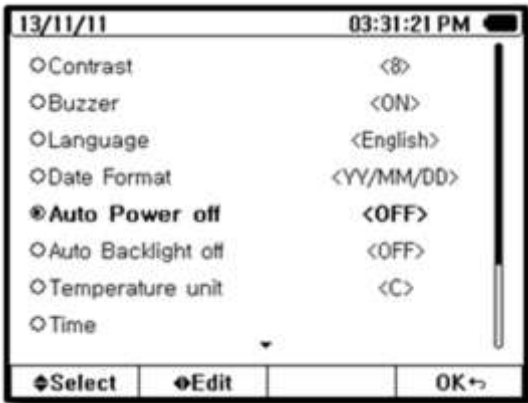

- When there is no input signal within the preset time, the power is automatically turned off.
- Auto power off time can be turned off or adjusted to a minimum of ten minutes to a maximum of one hour in menu set-up features.
- Any time power is supplied through AC adapter, the auto power off function is automatically off.
- Initial set-up (default) is set to off. Users can set-up desired time in menu mode.



[Menu Display]

11.2. Low Battery Warning

The remaining battery capacity of the NiMH rechargeable battery pack installed inside of SBS-6500 is displayed in a BARGRAPH in the upper right corner of the LCD display. This feature allows the user an estimation of the amount of battery time remaining before connection to the AC recharger is needed.

Indication	Status
	NiMH Battery is fully charged.
	After continuous use approx. 1 hours.
	After continuous use approx. 3~4 hours.
	After continuous use approx. 5~6 hours.
	No Remaining Power. Beeper sound.

[Remaining Battery Indication]

- When using the battery or the AC adaptor, the symbol for the source of power is displayed in upper right corner of the LCD screen.

11.3. Menu Mode

[Menu Set-Up Functions]

- Contrast Sets the screen contrast level.
- Buzzer Turns the audible sound on, off or mute.
- Language Allows help file language selection.
- Date Format Sets the date format.
- Auto Power Off Adjusts the auto power off timer or disables it.
- Auto Backlight Off Adjusts the auto backlight off timer or disables it.
- Temperature Unit Selects recording of F or C temperature units.
- Time Adjusts the real time clock setting of the CPU.
- Reset System Setting Restores settings to factory defaults.
- Erase Data **ERASES ALL DATA** from all data blocks in the entire memory.
- Device Information Displays firmware version and serial number of unit.

[Operation Procedure]

- ① Press **MENU** key to enter menu mode.
- ② Select function to adjust using the **▲** **▼** keys.
- ③ After the function is selected, change the setting by using the **◀** **▶** keys. Once the setting is changed to the desired value, press the **F4** EXIT key to complete setting and save.

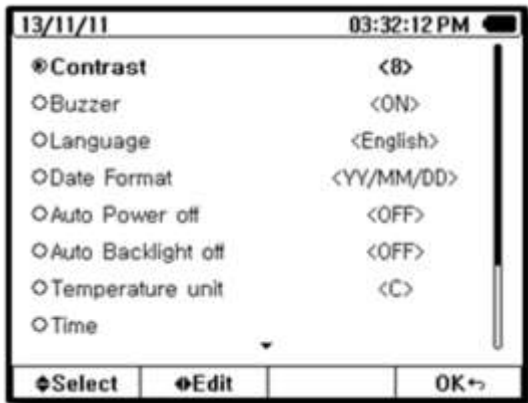

[Menu Initial Display]

[Contrast Adjust]

- Sets the brightness of the LCD screen: 1 to 15 steps
- Initial set-up (default) is set at eight steps

[Key Buzzer]

- Keyboard sound
- Initial set-up (default) is on
- Options are on, key sound off and mute

[Language]

- HELP language set-up
- Initial set-up is English

[Date Format]

- Display method: YY-MM-DD
- Initial set-up is YY-MM-DD, alternate is MM-DD-YY

[Time Setting]

- Time setting: hour-minute-second

[Auto Power Off]

- Auto power off time setting: off between ten minutes to one hour
- Initial setting (default) set at thirty minutes

[Temperature Unit]

- Temperature Unit can be selected °F/°C
- Initial (default) set-up is °F

[Device Information]

- Unit serial number
- F/W version number
- System format

[Factory Reset]



- Restores all menu items back to factory default values

11.4. HELP

Brief informational descriptions of each function are described in HELP mode.

HELP function scrolls to the entry related to the function currently in use.

[Operation Procedure]

- Press the HELP  key to open the HELP file text and an explanation is displayed on LCD screen.
- If HELP has multiple pages. Use the   keys or encoder switch to read the additional lines of text.
- To exit HELP press the EXIT key.

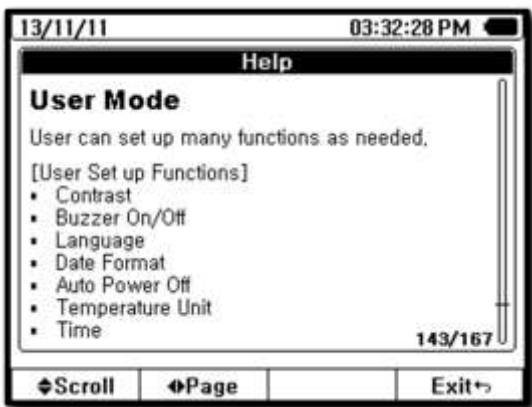

[HELP Display]

[Adapter]

- Main Power supply for the SBS-6500 is NiMH (7.2V) battery.
Use 2 x (3.6 V) battery Packs in the tester. When battery power is not available, AC Adapter (12 Vdc /1 amp) will also function as a power supply.
- When the AC adapter is connected to the SBS-6500 it supplies the power supply, while applying a recharge to the battery.
- When the analyzer is operated by AC adapter, the auto power off function is disabled.

12. SBS Battery Link Software

12.1. Description

SBS Battery Link Software is a powerful PC interface which is connected to the SBS-6500 via the supplied USB cable. Through the computer interface all of the features and controls of the SBS-6500 are mirrored in the remote control window. From the software, you can view or download data from the unit. Create reports of individual strings or detailed charts of a battery systems entire history. Software program can be installed from the supplied software CD or download the software program from manufacturer website. The website will always contain the most up to date version of the software.

12.2. Suggested Operation System

- Windows 7 or 8 recommended, XP is supported.
- True color (32 bit) or more
- Memory 128 MB or more
- HDD capacity 20MByte or more
- Interface USB Version 2.0

12.3. Connection between the SBS-6500 and the PC

Before connecting the SBS-6500 with the computer, install the SBS Battery Link Software on the PC. Follow the installation instructions and connect the unit with the supplied USB cable only when directed to do so.

- A USB cable with standard and mini USB connections is supplied with the SBS-6500.
- Drivers for USB communication are automatically installed as part of the software installation program.
- Only the USB cable supplied with the unit should be used for connection to the SBS-6500.

12.4. SBS Battery Link - Software Installation Procedure

- Insert the software (CD) into PC. Run the set-up program:



- User Authorization click YES.



- Click NEXT.



- Click INSTALL.
- The software will begin extracting files and installing them on the PC. The start driver install/update message should appear automatically.

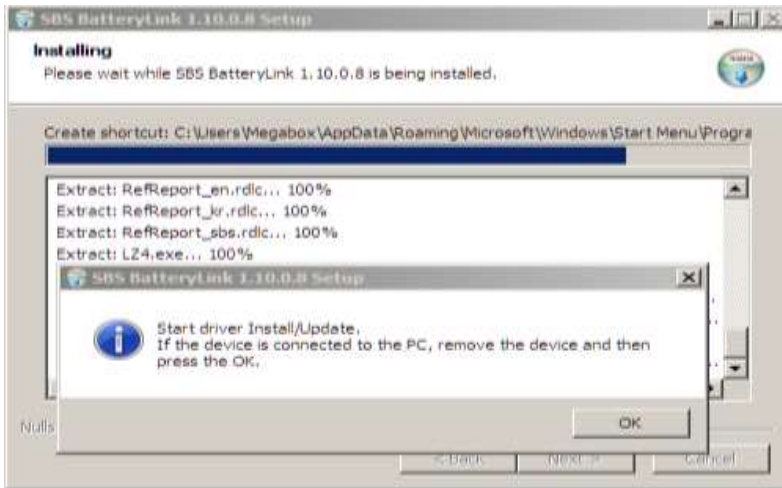

- Click OK to proceed with driver installation.

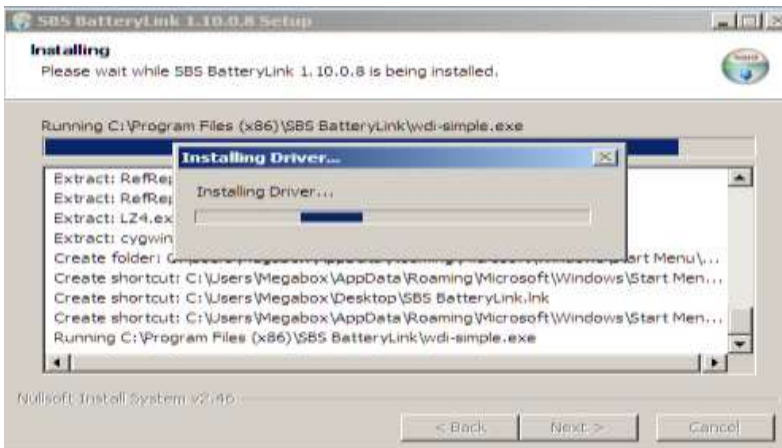

- Drivers for the SBS-6500 and USB connection will install automatically.

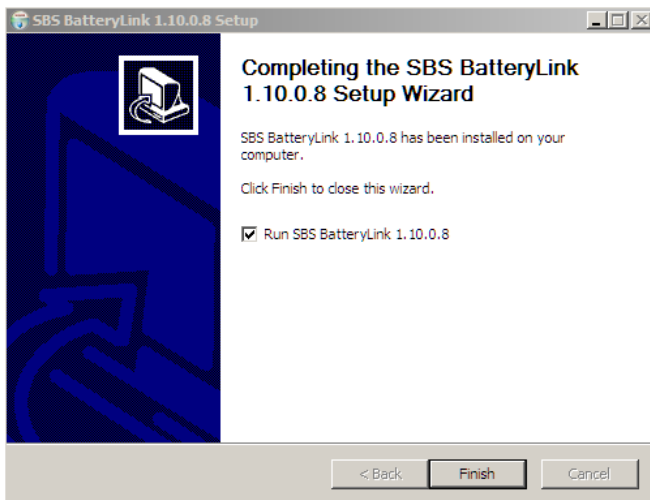

- A Setup Wizard Completed message will appear at the completion of driver installation. Click the FINISH key and the SBS Battery Link Software will run automatically.



- SBS Battery Link Icon will be added to the desktop.

12.5. Un-Installation of the SBS Battery Link software.

Disconnect the SBS-6500 from the PC prior to un-installing the software.

Go to "Start" - "Control Panel" - install/uninstall programs.

Select "SBS Battery Link "and click remove or un-install

12.6. Software Instructions

The SBS-6500 must be connected to the PC for the SBS-Battery Link Software to operate. This allows managers with multiple units to review histories and print reports without having to combine data from multiple SBS-6500's into a single data base. Each SBS-6500 unit will retain its own historical data in its internal memory.

- ① Connect the supplied USB cable between the SBS-6500 and the computer.
- ② Double click the SBS Battery Link Icon on the computer display screen.
The Software initial screen will be displayed, which instructs you to plug in the USB cable and power of the SBS-6500.

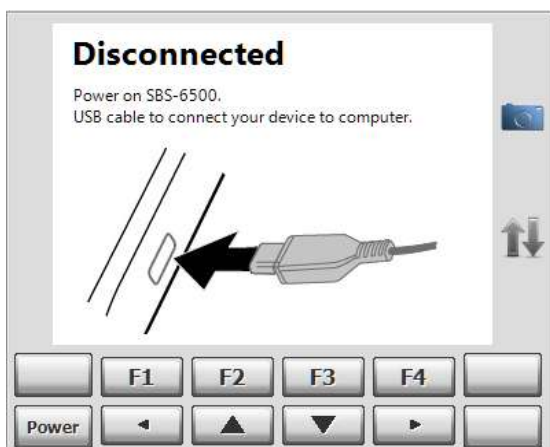

NOTE: When PC interface is working the auto power off feature is disabled.

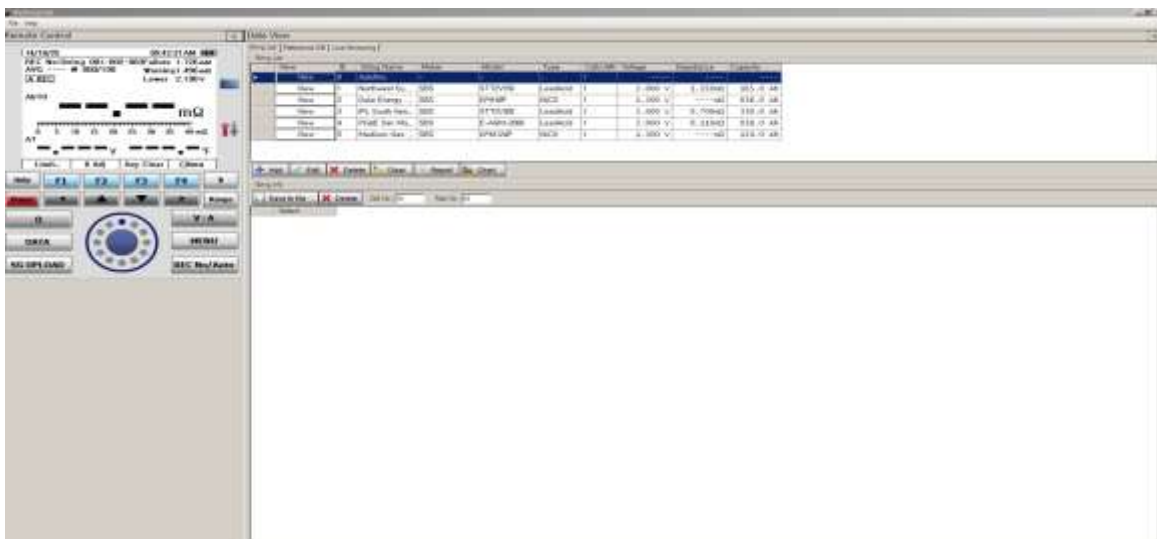

[Initial Screen]



Interface Program Structure

- The left hand block of the window is for remote control of the SBS-6500.

Control panel - all keys function by clicking of them with the mouse with the exception of the power key. The LCD screen of the SBS-6500 is displayed simultaneously in real time.

- Right hand block of window is the data view block. String list, Reference DB, live monitoring as well as the add/edit/delete/report and chart functions for each of the tabs.
- The control panel box can be minimized with key close or open  keys on the display.

1) Remote Control

- The remote control panel of the SBS-6500 Battery Link Software operates exactly the same as pushing the keys on the front of the tester.
- Screen capture key on the control panel  will take a screen snapshot and save it to a location of your choice.
- Interface data status indicator:  show data transmission from software to SBS-6500 and back simultaneously in real time.

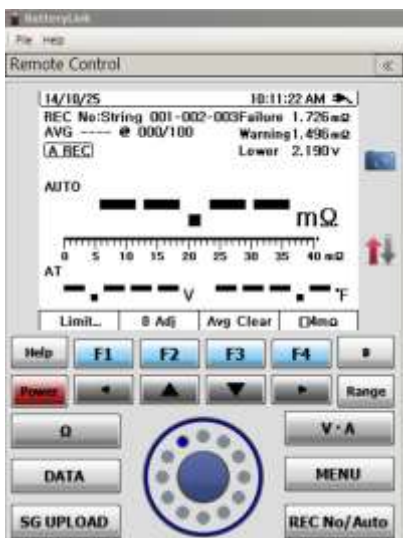

[Control Panel]

2) Management of Recorded Data

The Battery Link Software allows for management of the internal memory of the SBS-6500. All measurement values are recorded and retained on the unit. The software is a smart interface for organizing, reviewing, reporting and export of the data.

Data is stored and managed in the following manner.

- Memory is broken up into strings. A maximum of 300 namable strings can be programmed for identification of the measurements retained in each one. Each string can contain up to a maximum of 250 individual cell/battery measurements. Each of the individual cells/batteries can measure a total of 100 times over the life of the battery system.
- Addition, edit and deletion of string identifications and reference values.
- Viewing of recorded measurements in strings (impedance, voltages, temperature, specific gravity and condition results).
- Deletion of strings or reference values as they become obsolete.
- Measurement data - printing of reports, charts or exporting of data into Excel.

The screenshot shows the 'Data View' window with two main tables. The top table is the 'String List' and the bottom table is the 'String Data'.

String No.	String Name	Make	Model	Type	Cell Count	Voltage	Impedance	Capacity
1	Northwest St...	SBS	010/SB	LeadAcid	1	12.00 V	16.00mΩ	110.0 Ah
2	Dave Energy ...	SBS	KPM18P	AGD	1	1.200 v	-----Ω	035.0 Ah
3	PL South Ges...	SBS	0TT2/SB	LeadAcid	1	2.000 v	0.700mΩ	330.0 Ah
4	PG&E San Ma...	SBS	E-AGM-2000	LeadAcid	1	2.000 v	0.130mΩ	038.0 Ah
5	Madison Ges...	SBS	KPM12BP	AGD	1	1.200 v	-----Ω	124.0 Ah

String No.	Cell No.	Temp	Percent	Impedance	Volt	Gravity/Cond	Temp	Time
1	1	2	Warning	17.09mΩ	12.46 v	-----	076.3 °F	11/24/2014 9:14 AM
1	2	2	Warning	17.10mΩ	12.46 v	-----	076.3 °F	11/24/2014 9:14 AM
1	3	2	Warning	17.11mΩ	12.46 v	-----	076.3 °F	11/24/2014 9:14 AM
1	4	2	Warning	17.11mΩ	12.46 v	-----	076.3 °F	11/24/2014 9:14 AM
1	5	2	Warning	17.09mΩ	12.46 v	-----	076.4 °F	11/24/2014 9:14 AM
1	6	2	Warning	17.07mΩ	12.46 v	-----	076.4 °F	11/24/2014 9:14 AM
1	7	2	Warning	17.09mΩ	12.46 v	-----	076.5 °F	11/24/2014 9:15 AM
1	8	2	Warning	17.02mΩ	12.46 v	-----	076.5 °F	11/24/2014 9:15 AM
1	9	2	Warning	17.10mΩ	12.46 v	-----	076.5 °F	11/24/2014 9:15 AM
1	10	2	Warning	17.05mΩ	12.46 v	-----	076.5 °F	11/24/2014 9:15 AM

[String List Recorded Data Management Tab]

3) Reference DB

To determine battery condition and battery replacement criteria the measured data needs to be compared with reference values from the battery manufacturer for a new fully charged battery. DB entries can be input or modified (battery manufacturer, battery type, capacity, model number, voltages, impedance, etc.)

[Available functions from inside the software]

- Reference data base: Add, edit or delete reference entries.
- Export the contents of the Reference DB into an Excel file.
- Data base limit: Maximum of 200 entries arranged by the order they are input.

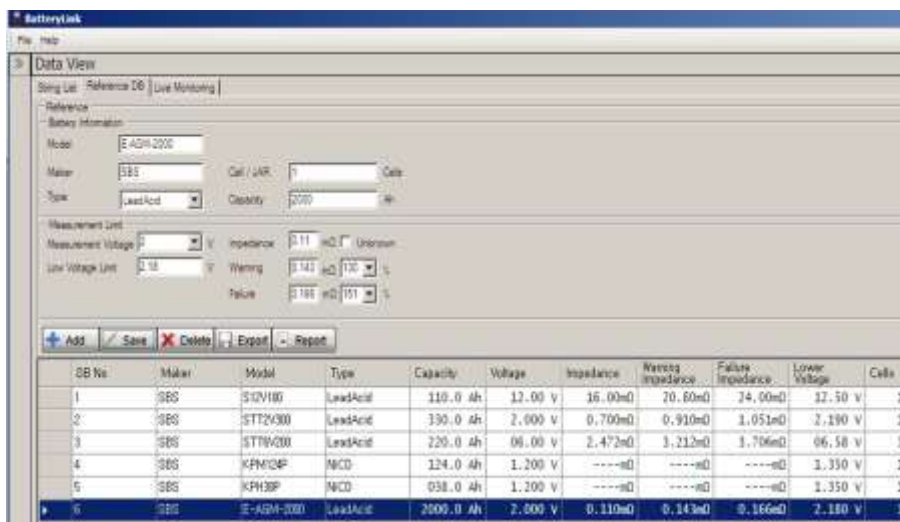

[Reference DB Management Tab]

4) Live Monitoring of SBS-6500

When the SBS-6500 is connected to the computer, the measurement data from the unit is transmitted to the software in real time. This could be a useful feature in specific instances of testing the instantaneous voltage rise on charge or drop on application of load.

- Measurement values displayed on the SBS-6500 are plotted on the software screen.
- Measurements and calculations values are displayed in the Index.
- Measurement values display in real time with timing counters.

- One to four graphs can be selected to simultaneously record. Maximum of four graphs can be drawn.
- Drawn graphs can be saved to a file on the PC.

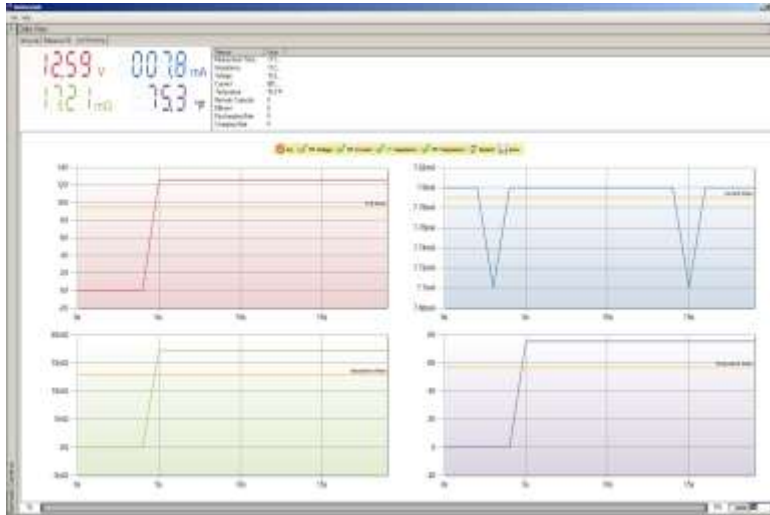

[PC Monitor]

5) Reporting

Report 

The SBS Battery Link software program includes a report generation feature.

There are two types of reports generated by the report key.

- Reference DB Entry Report

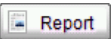
Press the  key on the Reference DB edit screen: This will generate a complete report of all of the programmed reference values with all of their parameters.

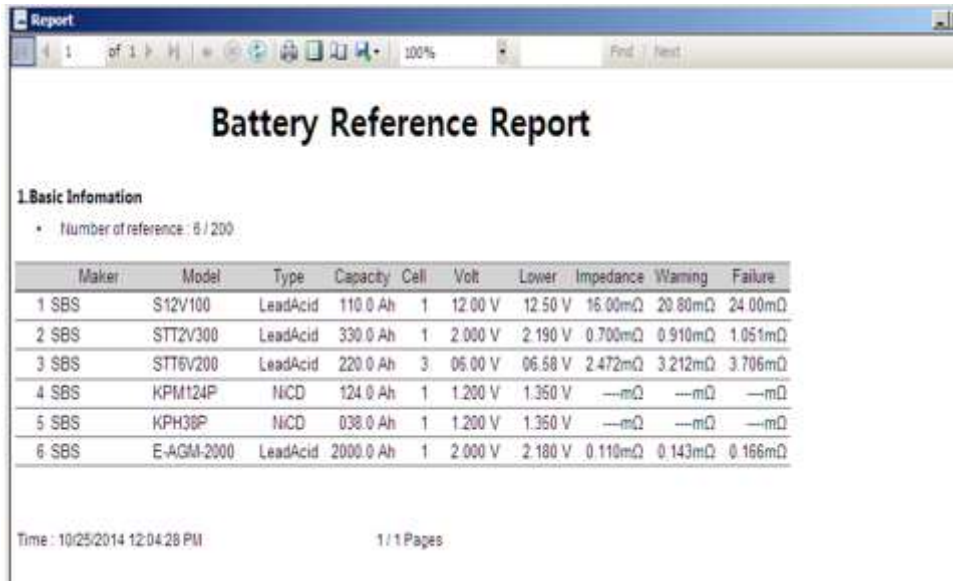

[Battery Reference DB Report]

- Test Report for a String

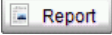
Press the  key on the string list tab: A report generation window will pop-up which allows you to select the string name and test number of the data that you want to populate the report.

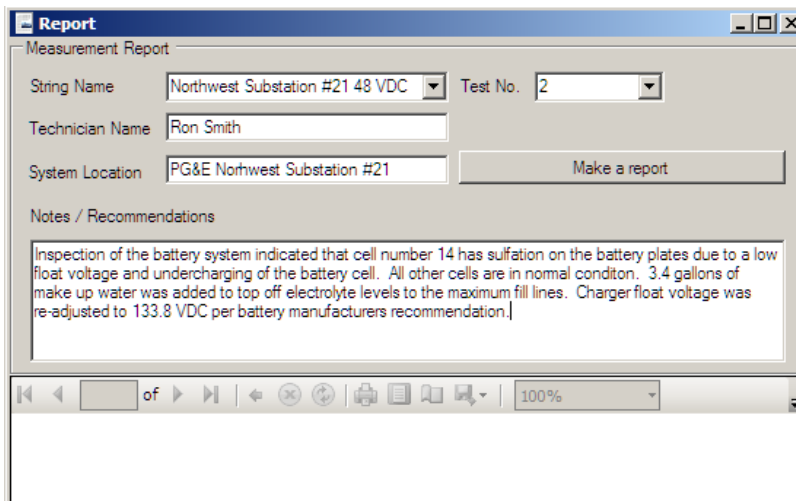

Select the string name of the report you want to generate.

Select the test number of the measurement data you want to merge into the report.

Enter technician's name, system location information and any notes or recommendations.

Click the "make a report" key to import the data and generate the battery condition report for that battery system.

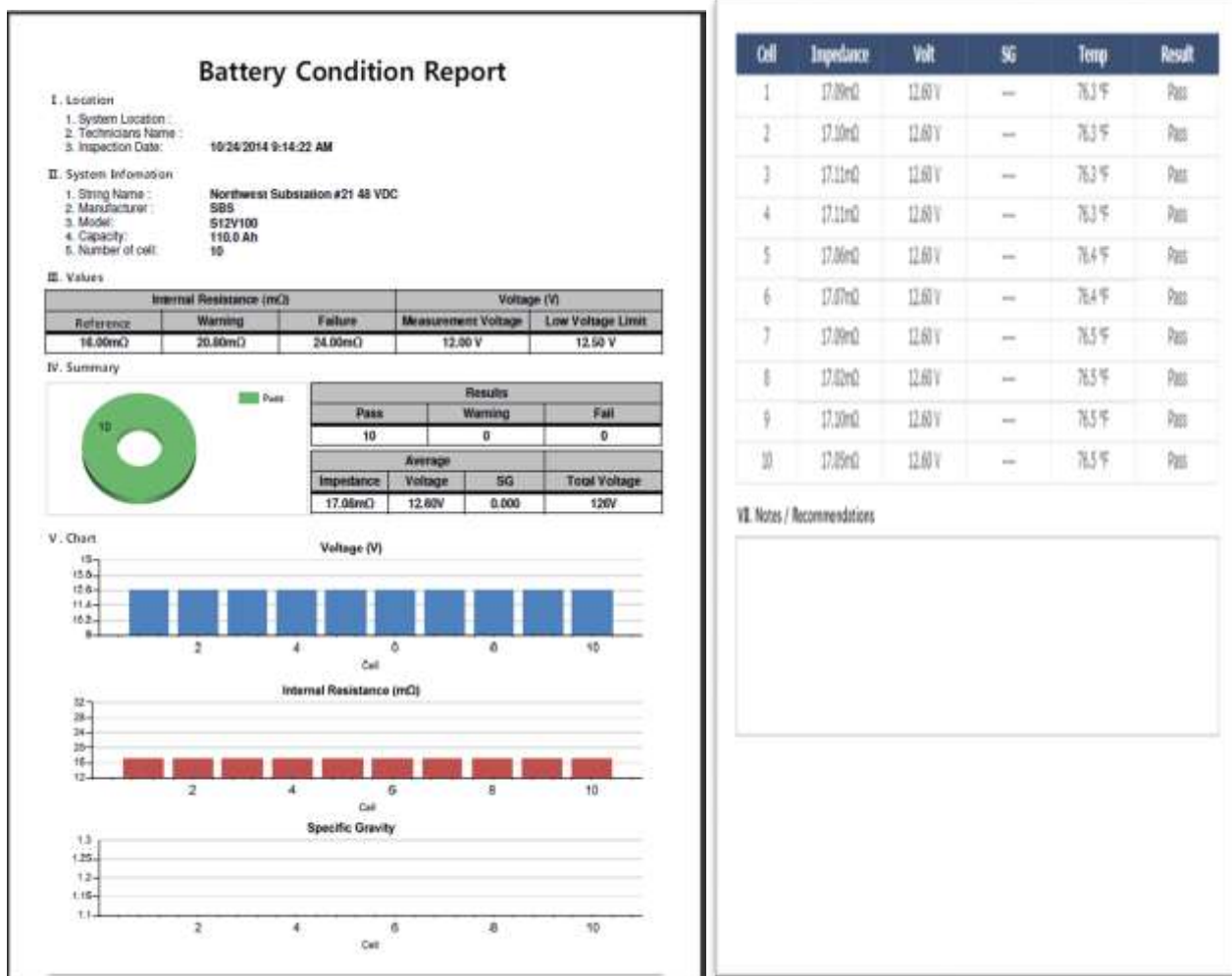

[Battery Measurement Condition Report]

The front page of the report will contain all of the string and location information as well as bar graphs for readings for voltage, internal resistance and specific gravity if taken with the SBS-2003 and imported into the SBS-6500. Additional pages of the report will show all of the individual measurements for every cell/battery in the system.

B) Chart  Reports

Accumulated measurement data can be displayed in 2D or 3D charts.

Press the  key.

Following data can be displayed in chart.

- History of the measurements for a single cell/ battery.
- Test comparison report, all the cells/batteries in a single string.
- String history comparison of changes in a cell over a period of time. Thirty cells x ten measurements at a time can be plotted for visualization.
- The charts allow mouse over to bring up data details by pointing to a specific bar on the chart.
- Condition results (pass, warning and fail) are displayed in different colors.

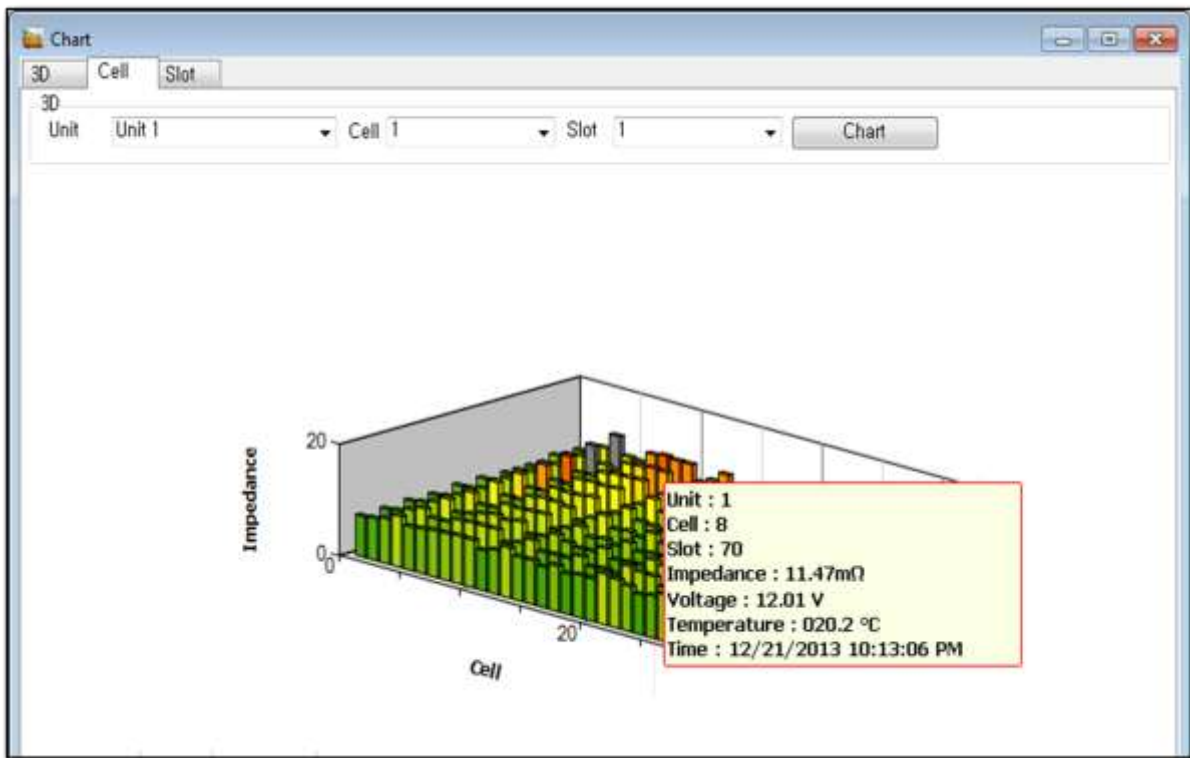

[3D Chart]

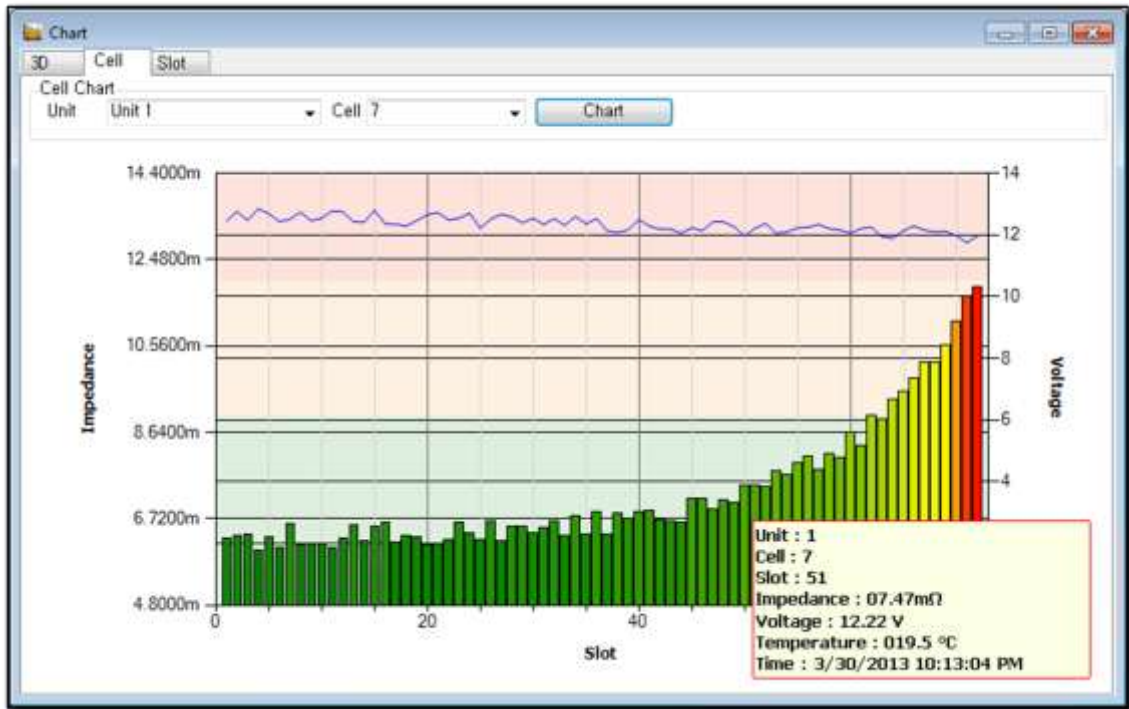

[Cell History Chart]



[String Comparison Chart]

6) Backup / Restore

The SBS Battery Link Software includes a memory backup/restore feature which makes a complete back up of everything held in the memory on the SBS-6500 and saves that data into a file on the PC for restoration at a later date and time.

Backup copies are filed by serial number of the unit, so backups can be controlled by managers over multiple SBS-6500's.

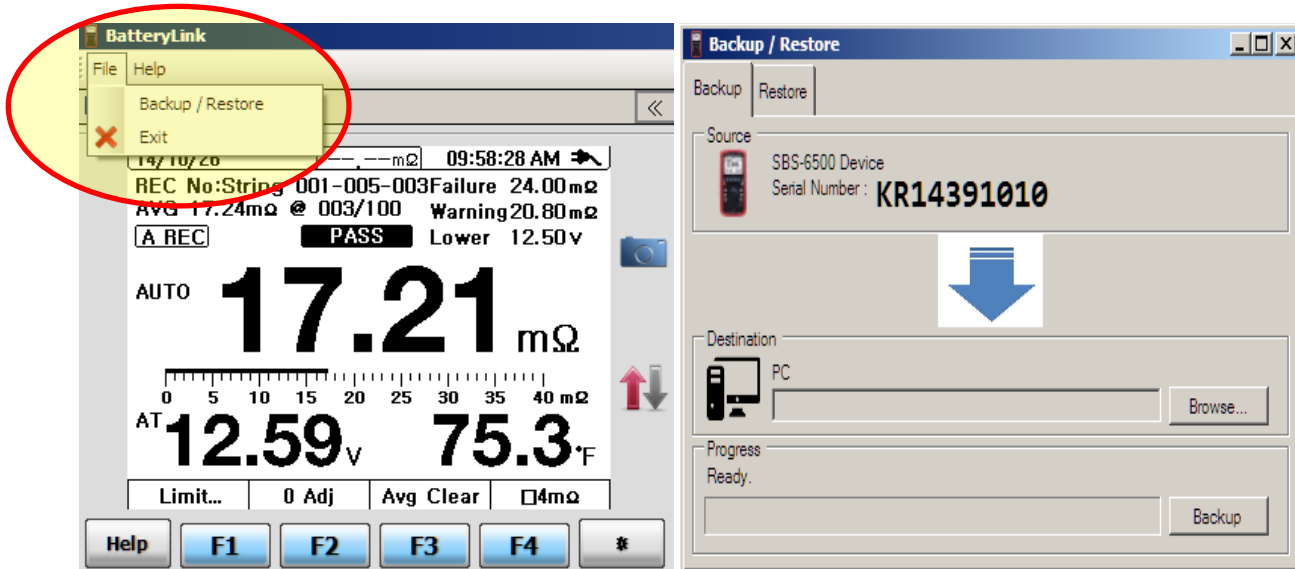

- Back up the SBS-6500 after the initial completion of your string list and Reference DB programming.
- Back up the SBS-6500 periodically to maintain a current back up copy of all measurements.
- Back up the SBS-6500 prior to sending the unit in for service.

12.7. Exiting Software

Click the X key  in the upper right of screen.

The SBS Battery Link Software will close. All changes made in the string list and Reference DB have been automatically saved to the SBS-6500. Unplug the USB and power off the SBS-6500.

13. Specifications

13.1. General Specifications

1) Special Features and Functions

- Battery internal resistance (impedance) measurement
- Battery terminal voltage (DC voltage measurement)
- Current (DC current) measurement (* with optional current clamp)
- Temperature measurement of the negative post
- Specific gravity integration (*With optional SBS-2003 digital hydrometer)
- 4-terminal measurement:
- SD card storage capacity enables to manage up max 7,530,000 historical records.
- Simultaneous measurement and battery condition determination
(Data and graphical display)
- Battery trend curve and analysis (impedance, voltage)
- Auto hold and data storage
- Enhanced analysis accuracy from data base (reference, background)
- Limit function (comparison) of impedance and voltage
- HELP screens for major functions
- 3.8" graphic mono LCD module (320 x 240 pixel)
- USB PC interface
- Sampling time: 10/sec
- Battery: 7.2V NiMH / 2.7A (2 x 3.6V NiMH/2.7A battery pack)
- Battery Life : Approximate 6 hours
- Battery full charging time : Approximately 5 hours

- AC Adapter: 100V ~ 240V/AC (automatic) output DC12VDC/1A.
- Operation temperature: 32°F ~ 104°F (0°C ~ 40°C), below 80% RH (No Dew)
- Storage temperature humidity: 15°F ~ 120°F (-10°C ~50°C), below 80% RH (No Dew)
- Temperature coefficient: 0.05 x (accuracy) / °F
- Max input voltage measurement terminals (electrodes) "+" ⇔ "-" Between electrodes:
Max DC 300V
- EMC : EN61326:1997+A1:1998+A2:2001+A3:2003
- Safety standard: EN61010-1: 2001 pollution degree two, measurement category II
(estimated over voltage 300V)
- Dimensions: 4.2" x 8.3 " x 2.2 " / 107mm × 220mm × 55mm
- Weight (main unit only): 2.2 lbs / 1.0kg

13.2. Electrical Specifications

[Guaranteed accuracy temperature condition]

- Accuracy is valid within 64°F ~ 82°F (18°C ~ 28°C), Relative Humidity Max 80% for 1 year.
- Accuracy Specifications: \pm ([% of reading] + [last digit number]).
- Impedance (internal resistance) measurement (auto/manual)

Range	Resolution	Current	Accuracy
+ 4m Ω	1 $\mu\Omega$	100mA	$\pm 1.0\% \text{rdg} \pm 10 \text{dgts}$
40m Ω	10 $\mu\Omega$	100mA	$\pm 0.8\% \text{rdg} \pm 10 \text{dgts}$
400m Ω	100 $\mu\Omega$	10mA	
4 Ω	1m Ω	10mA	

+ 4m Ω Range is manual ranging only.

Other ranges are auto/manual ranging

- ☞ Measurement current accuracy: $\pm 10\%$
- ☞ Measurement current frequency: 1kHz $\pm 30\text{Hz}$

When measuring impedance, voltage of the battery must be under 100V DC. Between 100Vdc ~ 150Vdc a warning will sound. If battery is over 150V, the protection circuit cuts off and Impedance measurement function shuts off.

- DC Voltage (Auto/Manual)

Range	Max Display	Resolution	Accuracy
4V	± 4	1mV	$\pm 0.5\% \text{rdg} \pm 5 \text{dgts}$
40V	± 40	10mV	
300V	± 300	100mV	

- Temperature

Range	Resolution	Accuracy
14° F~ 212 °F/ -10°C ~ 100°C	0.1°F / 0.1°C	N.S.

- DC Current

☞ CT (Through Current Adapter)

Range	Sensitivity	Resolution	Accuracy
40A	0.01A~40A	0.01A	±1%rdg±5dgts
400A	0.1A~ 400A	0.1A	

Total measurement accuracy reading may be added the own accuracy of the external current adapter

"A" unit is displayed on screen in mV

1mV equals to 1A. 10mV equals to 10A

[Accuracy]

Accuracy of measurement is identified fs (full scale), rdg. (reading), dgt. (digits)

- f.s.(maximum measurement value): Max measurement value on present range
- rdg. (measurement value): Present reading value
- dgt. (resolution): Least measurement unit

13.3. Accessories

- Pin type battery test probe (impedance, voltage measurement): 1 set
- USB Cable : 1
- PC Software (CD): 1

- Quick Start Guide : 1
- Operator Manual(CD): 1
- Carrying Bag: 1
- 0 Adjustment Board: 1
- NiMH Battery Back: 2 x 3.6V NiMH Battery Pack
- 120 VAC to 12VDC/1A Power adapter with internal charger
- Fuse (500mA, 5 x 20 mm): 1

13.4 Optional Accessories

- **SBS-2003 DIGITAL HYDROMETER**

SBS-2003

Bluetooth compatible Digital Hydrometer for importing specific gravity readings to the SBS-6500

- | | |
|-------------------------|--------------------|
| • Clamp style probe set | 6500-CLAMP-PROBE |
| • Replacement pin set | 6500-PIN-SET |
| • Current clamp | 6500-CURRENT-CLAMP |

14. Maintenance

[Warning]

Recommend to be performed only by qualified personnel to avoid possible electric shock or bodily injury. Do not attempt to repair the unit yourself. Opening the main body of the unit for any reason other than fuse or battery replacement will result in voiding the warranty period.

14.1. General Maintenance

- Clean the tester case with damp cloth and mild detergent periodically.
- Do not use abrasives, alcohols or solvents.
- Tip areas of test probes should always be cleaned off. Foreign material on the tip may cause a measurement error.

14.2. Fuse Replacement

[Warning]

To avoid electrical shock or bodily injury, remove any input signal from the test probes before replacing the Fuse. Fuse should be replaced only with a proper rated fuse.

[Replacement Procedure]

- ① Power OFF the SBS-6500.
- ② Disconnect test probes from battery terminals.
- ③ Remove holster case.
- ④ Open tilt stand and remove the two battery compartment cover screws.
- ⑤ Unscrew the screw at lower area of bottom case.
- ⑥ Open the bottom of the case.
- ⑦ Remove Used Fuse and replace with new fuse.
- ⑧ Reassemble in the reverse order of above steps.

14.3. Battery Replacement

[Warning]

To avoid electric shock or bodily injury, remove any input signal on test probes before replacing the batteries. Batteries should be replaced only with the same type of Battery Packs supplied with the SBS-6500.

[Replacement Procedure]

- ① Power Off the SBS-6500
- ② Disconnect any test probes, test Leads, temperature probes, AC power adapter, USB cable from the unit.
- ③ Remove holster case.
- ④ Open tilt stand and remove the screws from the two battery covers.

- ⑤ Remove battery packs and replace with new battery packs.
- ⑥ Make sure to match the (+, -) contacts of battery packs and (+, -) terminals in the battery compartments. Replace the battery covers.
- ⑦ Reassemble in the reverse order of the steps above.

14.4. Troubleshooting

In the event the unit is not functioning properly, check the following:

- ① Check battery polarity and that the batteries are fully charged.
- ② Inspect the case for physical signs of damage/cracks.
- ③ Check the fuse and test probes.
- ④ Contact technical support.

14.5. Test Probe Pin Replacement

When tip of the test probe is broke, damaged or abraded, replacement tips are available.

- ① Power off and separate test probes from the SBS-6500.
- ② Twist the head area where tip is threaded onto probe handle.



- ③ Pull on tip and separate tip from the lead wire.



- ④ Assemble the tip and test probe in the reverse steps as shown above.
- ⑤ Check the accuracy of measurement with the new tips. Zero "0" adjust the unit before taking measurements.

To prevent damage make sure the cables are tight with no movement of the pin tips or movement of the cable.

14.6. Cleaning

Use soft fabrics to clean by lightly dusting with damp cloth. Never use any type of solvent which could damage the unit.

14.7. Disposal

[Warning]

When disposing of the SBS-6500, separate the batteries which should be disposal of in accordance of regulations.

To avoid electrical shock, power off and separate batteries after the test probes are disconnected.

- ① Power off and separate test probes.
- ② Using a screw driver, remove screws from the battery covers.
- ③ Separate battery pack.

Recharge Adapter (Use for recharging purpose only, not for use for measurements)

- Input voltage: AC 100V~240V (free voltage)
- Output voltage: DC 12V/1A 50/60Hz

Battery Pack

- Voltage : 7.2V [NiMH 1.2V x3(3.6V) x 2 packs]
- Capacity: 2700mAh